

TECHNICAL MANUAL

OPERATOR'S MANUAL



**INTERCOMMUNICATION SET, VEHICULAR
AN/VIC-3(V), INCLUDING:**

Control, Indicator CD-82/VRC

(NSN 5895-01-382-3221) (EIC: NA)

Control, Intercommunication Set C-12357/VRC

(NSN 5830-01-382-3218) (EIC: NA)

Control, Intercommunication Set C-12358/VRC

(NSN 5830-01-382-3209) (EIC: NA)

Interface Unit, Communication Equipment C-12359/VRC

(NSN 5895-01-382-3220) (EIC: NA)

Loudspeaker, Permanent Magnet, LS-688/VRC

(NSN 5965-01-382-3222) (EIC: NA)

**Approved for public release; distribution is unlimited.
DESTRUCT NOTICE -- Destroy by any method that will prevent
disclosure of contents or reconstruction of the document**

HEADQUARTERS, DEPARTMENT OF THE ARMY

1 MAY 1997

CHANGE

No. 101

HEADQUARTERS
DEPARTMENT OF THE ARMY
WASHINGTON, DC, 1 MAY 2003

EXPIRES 1 MAY 2004

**OPERATOR'S MANUAL
for
INTERCOMMUNICATION SET, VEHICULAR AN/VIC-3(V)**

Control, Indicator CD-82/VRC
(NSN 5895-01-382-3221) (EIC: NA)
Control, Intercommunication Set C-12357/VRC
(NSN 5830-01-382-3218) (EIC: NA)
Control, Intercommunication Set C-12358/VRC
(NSN 5830-01-382-3209) (EIC: NA)
Interface Unit, Communication Equipment C-12359/VRC
(NSN 5895-01-382-3220) (EIC: NA)
Loudspeaker, Permanent Magnet LS-688/VRC
(NSN 5965-01-382-3222) (EIC: NA)

TM 11-5830-263-10, 1 May 1997, is changed as follows:

1. New or changed text is indicated by a vertical bar in the margin of the page.
2. Remove old pages and insert new pages:

Remove Pages

A/(B blank)
None
2-9/2-10
None
2-11/2-12
2-19/2-20
None
3-3/3-4
3-4.1/3-4.2

Insert Pages

A/(B blank)
c/(d blank)
2-9/2-10
2-10.1/(2-10.2 blank)
2-11/2-12
2-19/2-20
(2-20.1 blank)/2-20.2
3-3/3-4
3-4.1 thru 3-4.3/(3-4.4 blank)

3. File this sheet in front of the publication for reference purposes.

Approved for public release; distribution is unlimited.

By Order of the Secretary of the Army:

Official:

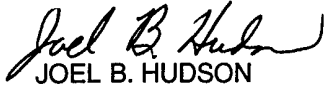

JOEL B. HUDSON

*Administrative Assistant to the
Secretary of the Army*

05985

ERIC K. SHINSEKI
*General, United States Army
Chief of Staff*

DISTRIBUTION:

To be distributed in accordance with the initial distribution number (IDN) 369732 requirements for TM 11-5830-263-10.

CHANGE
NO. 1

HEADQUARTERS,
DEPARTMENT OF THE ARMY
WASHINGTON, D.C. 1 JULY 2000

OPERATOR'S MANUAL
for
INTERCOMMUNICATION SET, VEHICULAR AN/VIC-3(V)

Control, Indicator CD-82/VRC
(NSN 5895-01-382-3221) (EIC: NA)
Control, Intercommunication Set C-12357/VRC
(NSN 5830-01-382-3218) (EIC: NA)
Control, Intercommunication Set C-12358/VRC
(NSN 5830-01-382-3209) (EIC: NA)
Interface Unit, Communication Equipment C-12359/VRC
(NSN 5895-01-382-3220) (EIC: NA)
Loudspeaker, Permanent Magnet LS-688/VRC
(NSN 5965-01-382-3222) (EIC: NA)

TM 11-5830-263-10, 1 May 1997, is changed as follows:

1. New or changed text is indicated by a vertical bar in the margin of the page.
2. Remove old pages and insert new pages:

Remove Pages

None
i and ii
Blank and 1-0
1-3 and 1-4
1-7 thru 1-10
1-11/(1-12 blank)
2-19 and 2-20
3-1 thru 3-4
None
A-1 thru A-4
Cover 1

Insert Pages

A and B(blank)
i and ii
iii and 1-0
1-3 and 1-4
1-7 thru 1-10
None
2-19 and 2-20
3-1 thru 3-4
3-4.1 and 3-4.2
A-1 thru A-4
Cover 2

3. File this sheet in front of the publication for reference purposes.

By Order of the Secretary of the Army:

Official:

JOEL B. HUDSON
*Administrative Assistant to the
Secretary of the Army*
0022310

ERIC K. SHINSEKI
*General, United States Army
Chief of Staff*

DISTRIBUTION:

To be distributed in accordance with the initial distribution number (IDN) 369732 and special requirements for TM 11-5830-263-10.

LIST OF EFFECTIVE PAGES/WORK PACKAGES

Dates of issue for the original manual and changed pages/work packages are:

Original 1 May 97
 Change 1 1 July 00
 Change I01 1 May 03

TOTAL NUMBER OF PAGES FOR FRONT AND REAR MATTER IS 18 AND TOTAL NUMBER OF WORK PACKAGES IS 0, CONSISTING OF THE FOLLOWING:

Page/WP No.	*Change No.	Page/WP No.	*Change No.
Cover/blank	1	2-12 thru 2-18	0
A/(B blank)	I01	2-19 and 2-20	I01
a/b)	0	(2-20.1 blank) and 2-10.2	I01
c/(d blank)	I01	2-21 thru 2-40	0
i and ii	1	Chapter 3	
iii	1	3-1	0
1-0	0	3-2	1
Chapter 1		3-3 and 3-4	I01
1-1 and 1-2	0	3-4.1 thru 3-4.3/ (3-4.4 blank)	I01
1-3	1		
1-4 thru 1-7	0	3-5 and 3-6	0
1-8	1	A-1 thru A-3	1
1-9	1	A-4	0
1-10	0	B-1 and B-2	0
1-11 and 1-12 Deleted	1	C-1 and C-2	0
Chapter 2		D-1 and D-2	0
2-1 thru 2-9	0	E-1 and E-2	0
2-10	I01		
2-10.1 and 2-10.2	I01		
2-11	I01		

*Zero in this column indicates an original page.



5

SAFETY STEPS TO FOLLOW IF SOMEONE IS THE VICTIM OF ELECTRICAL SHOCK

DO NOT TRY TO PULL OR GRAB THE INDIVIDUAL

2

IF POSSIBLE, TURN OFF THE ELECTRICAL POWER

3

IF YOU CANNOT TURN OFF THE ELECTRICAL POWER, PULL, PUSH, OR LIFT THE PERSON TO SAFETY USING A DRY WOODEN POLE OR A DRY ROPE OR SOME OTHER INSULATING MATERIAL

4

SEND FOR HELP AS SOON AS POSSIBLE

5

AFTER THE INJURED PERSON IS FREE OF CONTACT WITH THE SOURCE OF ELECTRICAL SHOCK, MOVE THE PERSON A SHORT DISTANCE AWAY AND IMMEDIATELY START ARTIFICIAL RESUSCITATION

WARNING

HIGH VOLTAGE

IS USED IN THE OPERATION OF THIS EQUIPMENT.

DEATH ON CONTACT

MAY RESULT IF PERSONNEL FAIL TO OBSERVE SAFETY PRECAUTIONS.

DO NOT BE MISLED BY THE TERM "LOW VOLTAGE". POTENTIALS AS LOW AS 30 VOLTS MAY CAUSE DEATH UNDER CERTAIN CONDITIONS.

FOR ARTIFICIAL RESPIRATION, REFER TO FM 21-11.

WARNING

WHEN LISTENING TO THE VIS RADIO HEADSET WITH THE OPERATOR VOLUME CONTROLS SETTING IN THE RED ZONE CLICK STOP AT A FULL ON VOLUME SETTING, EXTREME CAUTION MUST BE EXERCISED TO PREVENT NOISE-INDUCED HEARING LOSS. EXPOSURES TO RADIO SIGNALS IN THE FULL ON POSITION BEYOND 45 SECONDS MAY CAUSE HEARING LOSS. ANY PROLONGED EXPOSURE IN THE FULL ON VOLUME CONTROL SETTING REQUIRES THE USE OF A SINGLE HEARING PROTECTIVE DEVICE IN EACH EAR.

WARNING

ALKALINE BATTERIES CONTAIN CAUSTIC KOH ELECTROLYTE, WHICH MAY LEAK IF THE BATTERY IS ABUSED. KOH IS A STRONG ALKALI SIMILAR TO CAUSTIC SODA (SODIUM HYDROXIDE). SERIOUS CHEMICAL BURNS CAN RESULT IF ELECTROLYTE COMES INTO CONTACT WITH THE SKIN OR EYES. IF THE BATTERY ELECTROLYTE GETS INTO YOUR EYES, IT CAN CAUSE SEVERE DAMAGE AND/OR BLINDNESS.

DO NOT TRY TO NEUTRALIZE CAUSTIC ELECTROLYTE WITH VINEGAR OR ANY OTHER ACIDIC SOLUTIONS. NEUTRALIZATION WILL DO MORE HARM THAN GOOD, AS IT WILL TRAP CAUSTIC UNDER THE SKIN, PREVENTING IT FROM COMING OUT. FLUSH WITH COPIOUS AMOUNTS OF COOL WATER.

WARNING

DISCONNECTING OR BYPASSING THE VEHICULAR INTERCOMMUNICATION SYSTEM (VIS) ALARM CABLE CONNECTED TO THE DRIVER'S FULL FUNCTION CREW STATION (FFCS) BY THE VEHICLE CREWMAN IS PROHIBITED. SUCH ACTION MAY RESULT IN INJURY OR DEATH. EQUIPMENT DAMAGE MAY ALSO RESULT. THIS CABLE ENABLES THE VEHICLE HAZARD WARNING TONES TO BE INSERTED DIRECTLY INTO THE INTERCOM SYSTEM, SO THAT THESE WARNING TONES CAN BE INSTANTLY HEARD BY ALL OF THE VEHICLE CREWMEMBERS. ONLY THE UNIT MAINTAINER IS AUTHORIZED TO REMOVE AND REPLACE THE ALARM CABLE. REFER TO THE APPROPRIATE VIS TECHNICAL PUBLICATIONS FOR OPERATOR, INSTALLATION, AND MAINTENANCE INSTRUCTIONS.

**OPERATOR'S MANUAL
for
INTERCOMMUNICATION SET, VEHICULAR AN/VIC-3(V)**

Control, Indicator CD-82/VRC

(NSN 5895-01-382-3221) (EIC: NA)

Control, Intercommunication Set C-12357/VRC

(NSN 5830-01-382-3218) (EIC: NA)

Control, Intercommunication Set C-12358/VRC

(NSN 5830-01-382-3209) (EIC: NA)

Interface Unit, Communication Equipment C-12359/VRC

(NSN 5895-01-382-3220) (EIC: NA)

Loudspeaker, Permanent Magnet LS-688/VRC

(NSN 5965-01-382-3222) (EIC: NA)

REPORTING ERRORS AND RECOMMENDING IMPROVEMENTS

You can help improve this manual. If you find any mistakes, or if you know of a way to improve the procedures, please let us know. Mail your letter, DA Form 2028 (Recommended Changes to Publications and Blank Forms) or DA Form 2028-2 located in back of this manual direct to: Commander, US Army Communications-Electronics Command and Fort Monmouth, ATTN: AMSEL-LC-LEO-D-CS-CFO, Fort Monmouth, New Jersey 07703-5007. The fax number is 732-532-1413, DSN 992-1413. You may also e-mail your recommendations to AMSEL-LC-LEO-PUBS-CHG@cecom3.monmouth.army.mil

For Air Force, submit AFTO Form 22 (Technical Order System Publication Improvement Report and Reply) in accordance with paragraph 6-5, Section VI, TO 00-5-1. Forward direct to prime ALC/MST.

For Navy, mail comments to the Commander, Space and Naval Warfare Systems Command, ATTN: SPAWAR 8122, Washington, DC 20363-5100.

Marine Corps units, submit NAVMC 10772 (Recommended Changes to Technical Publications) to: Commanding General, Marine Corps Logistics Base (Code 850), Albany, Georgia 31704-5000.

In either case a reply will be furnished direct to you.

TABLE OF CONTENTS

	Page
How To Use This Manual.....	iii
Chapter 1 Introduction	1-1
Section I. General Information	1-1
Section II. Principles of Operation	1-3
Section III. Equipment Description and Data	1-5
Section IV. Training Interfaces	1-11
Chapter 2 Operating Instructions.....	2-1
Section I. Controls and Indicators	2-1
Section II. Operating Procedures Under Normal Conditions	2-22
Section III. Operation Under Unusual Conditions	2-40

TABLE OF CONTENTS (continued)

	Page
Chapter 3 Operator Maintenance Instructions.....	3-1
Section I. Operator Preventive Maintenance Checks and Services (PMCS).	3-1
Section II. Operator Troubleshooting Procedures	3-5
APPENDIX A REFERENCES	A-1
APPENDIX B COMPONENTS OF END ITEM AND BASIC ISSUE ITEMS LIST ..	B-1
APPENDIX C ADDITIONAL AUTHORIZATION LIST.....	C-1
APPENDIX D EXPENDABLE/DURABLE SUPPLIES AND MATERIALS LIST.....	D-1
APPENDIX E ACRONYMS AND TERMS.....	E-1

HOW TO USE THIS MANUAL

LOCATING INFORMATION

TABLE OF CONTENTS. Refer to the Table of Contents to find out where information can be found.

ABBREVIATIONS. Refer to the list of abbreviations in Appendix E in the back of this manual to find the term associated with an unfamiliar abbreviation.

NOMENCLATURE CROSS-REFERENCE LIST. Refer to the nomenclature cross-reference list in Table 1-1 on page 1-2 to find common names and official nomenclature.

WARNING PAGES are at the beginning of this manual. You should learn the warnings before using the equipment. Always follow appropriate safety procedures and precautions.

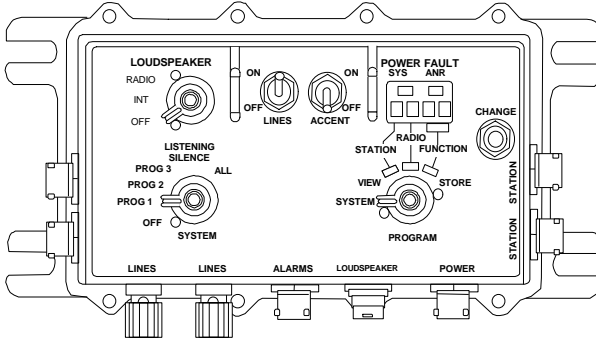

MASTER CONTROL STATION (MCS)

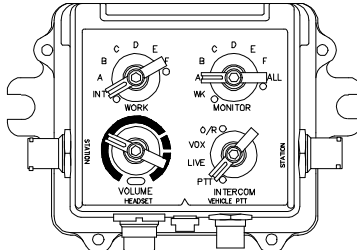

FULL FUNCTION CREW STATION (FFCS)

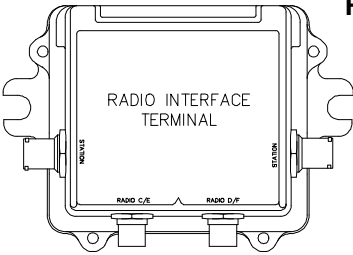

RADIO INTERFACE TERMINAL (RIT)

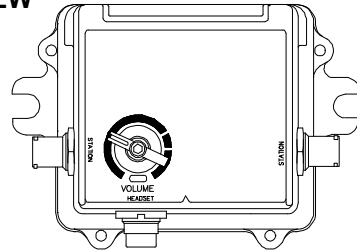

MONITOR ONLY STATION (MOS)

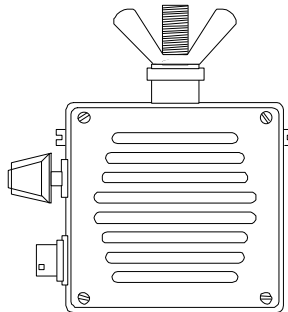

LOUDSPEAKER (LS)

CHAPTER 1 INTRODUCTION

	Page
Section I. General Information	1-1
Section II. Principles of Operation.....	1-3
Section III. Equipment Description and Data.....	1-5
Section IV. Training Interfaces	1-11

SECTION I. GENERAL INFORMATION

1.1. SCOPE

- a. Type of Manual: Operator's Manual
- b. Model Number and Equipment Name. The official nomenclature is the AN/VIC-3(V) Intercommunication Set, with its common name being the Vehicular Intercommunication System (VIS). There are many current and future variations of this system designed for specific vehicles and/or platforms, each with its own unique technical bulletin for installation. The first vehicle/platform is designated the AN/VIC-3(V)1, the second is designated AN/VIC-3(V)2, and so on, with their corresponding technical bulletins designated TB 11-5830-263-20-1, TB 11--5830-263-20-2, and so on. These vehicle/platform specific variations have meaning only to the installation team as the system loses its identity when installed. Any vehicle/ platform that has this system installed is referred to as having the VIS or "VIC-3" (AN/VIC-3(V)).
- c. Purpose of Equipment: The AN/VIC-3(V) Intercommunication Set, hereinafter referred to as VIS, is an intercommunication and radio-control system designed for ground mobile combat vehicles. Digital audio enhances speech quality and intelligibility. Headsets that incorporate active noise reduction (ANR) circuitry increase the effectiveness of vehicle communications. They offer increased hearing protection in the noisy environment of combat vehicles.

1.2. CONSOLIDATED INDEX OF ARMY PUBLICATIONS AND BLANK FORMS

Refer to latest issue of DA Pam 25-30 to determine whether there are new editions, changes, or additional publications pertaining to the equipment.

1.3. MAINTENANCE FORMS, RECORDS, AND REPORTS

Reports of Maintenance and Unsatisfactory Equipment. Department of the Army forms and procedures used for equipment maintenance will be those prescribed by DA PAM 738-750 as contained in Maintenance Management Update.

1.4. REPORTING EQUIPMENT IMPROVEMENT RECOMMENDATIONS (EIR)

If your AN/VIC-3 (V) INTERCOMMUNICATION SET needs improvement, let us know. Send us an EIR. You, the user, are the only one who can tell us what you don't like about the design. Put it on an SF 368 (Product Quality Deficiency Report). Mail it to: Commander, US Army Communications-Electronics Command and Fort Monmouth, ATTN: AMSEL-LC-LEO-P-MM-T, Fort Monmouth, NJ 07703-5023. THE FAX NUMBER is 908-532-3421, DSN 992-3421. You may also e-mail your recommendations to: AMSEL-LC-LEO-PUBS-CHG@CECOM3.MONMOUTH.ARMY.MIL. We'll send you a reply.

1.5. ADMINISTRATIVE STORAGE

Administrative storage of equipment issued to and used by Army activities will have preventive maintenance performed according to Chapter 3, Section I, Preventive Maintenance Check and Services (PMCS) charts before storing. When removing equipment from administrative storage, assure operational readiness by performing PMCS. Disassembly and repacking of equipment for shipment or limited storage is covered in the procedures for the vehicle.

1.6. DESTRUCTION OF ARMY ELECTRONICS MATERIAL

Destruction of Army electronics material to prevent enemy use shall be in accordance with TM 750-244-2 and AR 380-5.

1.7 NOMENCLATURE CROSS REFERENCE/Common Names List

Table 1-1. Nomenclature Cross Reference List

COMMON NAME	OFFICIAL NOMENCLATURE
Vehicular Intercommunications System AN/VIC-3(V)	Intercommunication Set AN/VIC-3(V)
Master Control Station (MCS)	Control Indicator CD-82/VRC
Full Function Crew Station (FFCS)	Control Intercommunication Set C-12357/VRC
Monitor Only (Crew) Station (MOS)	Control Intercommunication Set C-12358/VRC
Radio Interface Terminal (RIT)	Interface Unit, Communication Equipment C-12359/VRC
Combat Vehicle Crewman's (Headset) (CVC)	Headset-Microphone H-374/VRC
Product Improved Combat Vehicle Crewman's (Headset) (PICVC)	Headset Microphone H-374/VRC
Communication Aural Protective System (Headset) (CAPS)	CAPS (TYPE I) H-365/VRC CAPS (TYPE II) H-366/VRC
Artillery Communication Aural Protective System (Headset) (ACAPS)	ACAPS (TYPE B) H-370/VRC
Command and Control Headset (CCH)	Headset-Microphone H-364/VRC
Loudspeaker (LS)	LOUDSPEAKER LS-688/VRC

SECTION II. PRINCIPLES OF OPERATION

1.8. GENERAL OVERVIEW OF SYSTEM OPERATION

Each version of the AN/VIC-3(V), Vehicular Intercommunication System (VIS) is made up of members of a family of common boxes interconnected by highway cables in either a ring or two-branch configuration as shown in figure 1-1. Specific configuration details depend upon the type of vehicle into which the system is installed. Each system contains one Master Control Station (MCS), up to six Full Function Crew Stations (FFCS) and one Loudspeaker (LS). Up to four Monitor Only Stations (MOS) and/or up to two Radio Interface Terminals (RIT) (if one to four additional radios are being utilized) may also be added. Each system also contains headsets for each FFCS and MOS in the configuration, which vary in type depending upon the specific vehicle configuration requirements. (For specific characteristics of the individual components for the VIS refer to Section III, Chapter 1) Neither the ring or two-branch configuration relies on individual units (boxes) to re-transmit data. If any unit within the system becomes inoperable it does not necessarily interfere with the operation of the rest of the system. The ring configuration provides additional survivability by an automatic reconnect feature that changes from the ring configuration to the two-branch configuration if a highway cable is broken or disconnected.

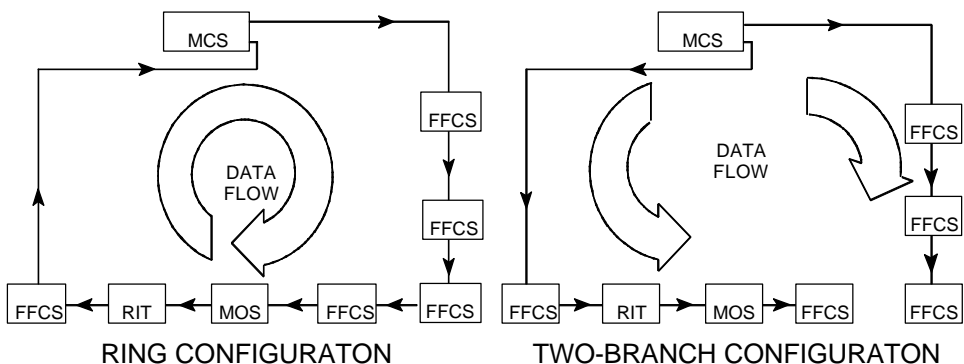

Figure 1-1. VIS Configuration Types

1.9. SYSTEM COMPONENTS

Each version of the VIS contains a mixture of the following items in varying quantities, uniquely configured for a specific vehicle or platform. (See Figure 1-2 for example).

- Master Control Station (MCS)
 - Full Function Crew Station (FFCS)
 - Monitor Only (Crew) Station (MOS)
 - Radio Interface Terminal (RIT)
 - Loudspeaker, Permanent Magnet (LS)
 - Four types of headsets
- a. Combat Vehicle Crewman (CVC), including Product Improved CVC (PICVC)
 - b. Crew Aural Protective System (CAPS)
 - c. Artillery Crew Aural Protective System (ACAPS)
 - d. Command and Control headset (CCH)

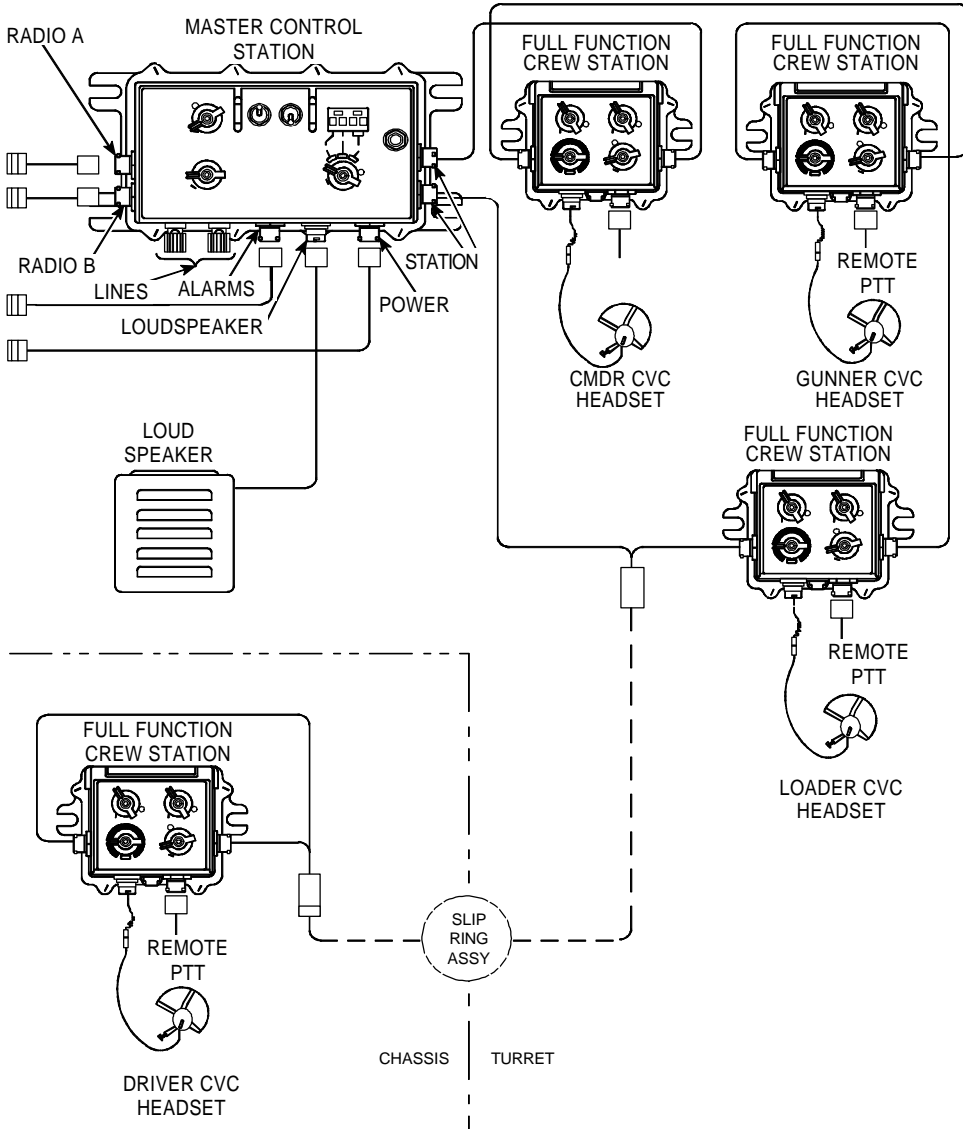

Figure 1-2. Typical VIS Configuration

SECTION III. EQUIPMENT DESCRIPTION AND DATA

1.10. EQUIPMENT CHARACTERISTICS, CAPABILITIES, AND FEATURES

In addition to the components listed in Para.1.9 the VIS system has the following characteristics:

- System highway bus
- Active Noise Reduction (ANR) circuitry incorporated into headsets
- Noise canceling microphones
- Live, Voice Operated (VOX), and Push-To-Talk (PTT) microphone modes of operation
- Increased speech intelligibility
- Built-In-Test (BIT) and Continuous Performance Monitoring (CPM)
- Auto Reconnect Circuit (ARC)

1.10.1. MASTER CONTROL STATION (MCS)

Each system contains one programmable MCS, the central node of the VIS, that connects to the vehicle prime power through the radios/radio mount. The MCS controls and monitors overall operation by providing the rest of the system with regulated power, audio, and control signals via the highway cables. Access to on-board radios, for each crewstation, is accomplished through programming of the MCS. The MCS provides connections for two radio transceivers, vehicle alarms, loudspeaker, and a pair of field wires (used to connect to a field telephone or another MCS).

The MCS programming capability allows for various communications configurations. Programming information is stored to memory so the system can be turned off without losing any programming information. The MCS displays operating status and deviations from stored configuration detected by Built-In-Test (BIT) and Continuous Performance Monitoring (CPM). It checks for the normal response from each FFCS (and RITs if utilized) for comparison with the system configuration programmed into memory.

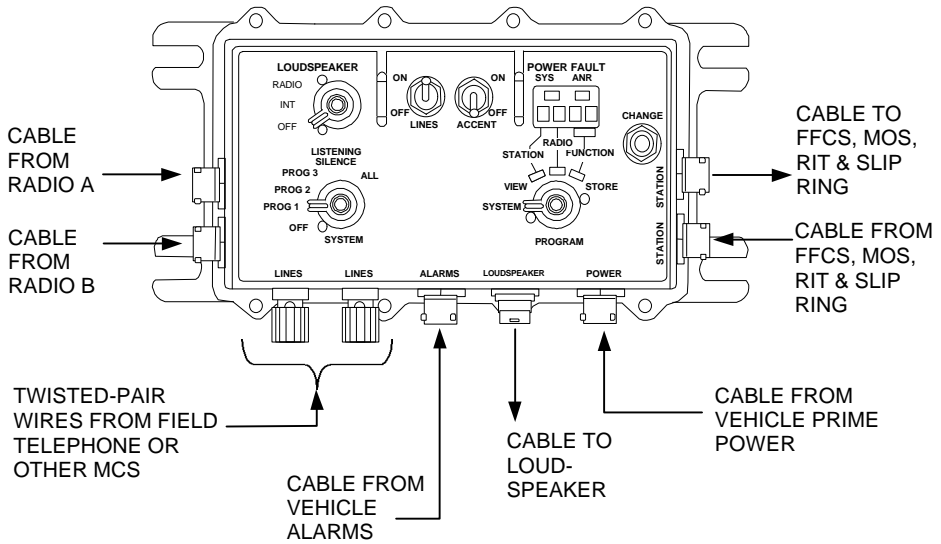

Figure 1-3. Master Control Station (MCS)

1.10.2. FULL FUNCTION CREW STATION (FFCS)

The FFCS is the interface between the VIS system and a single headset. It allows a crewmember to communicate through the intercom and/or radios (subject to MCS programming access). It allows independent volume control as well as selection of the transmitting mode such as Push-To-Talk (PTT), LIVE, Voice Activated Transmission (VOX), and Override (O/R). LIVE, VOX, and O/R are used for intercom transmission only. The vehicle or headset PTT switch must be utilized for transmission over the radios, or for the intercom when the FFCS WORK switch is set to INT and the INTERCOM switch is set to PTT. A Loudspeaker (LS) may be attached to the HEADSET connector of the FFCS for listen-only communication.

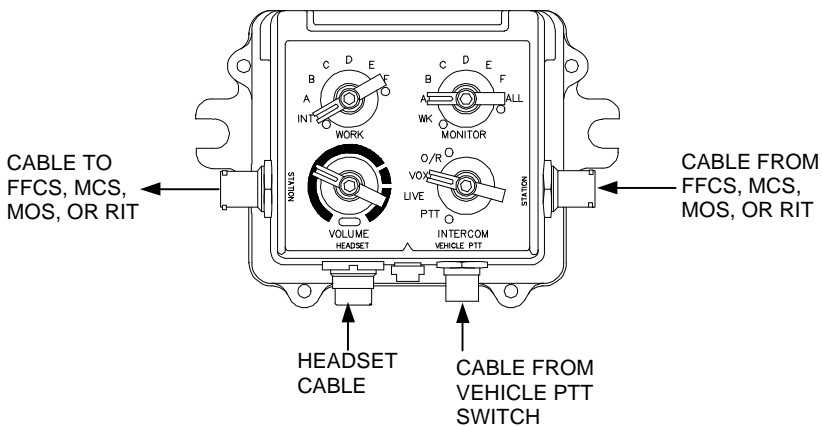

Figure 1-4. Full Function Crew Station (FFCS)

1.10.3 Radio Interface Terminal

The RIT provides an interface for up to two additional radio transceivers. This unit enables the basic two-radio system to expand to accommodate up to four additional radios (using two RITs). Currently the VIS system can accommodate a maximum of six radios. There are no operator adjustable controls on the RIT.

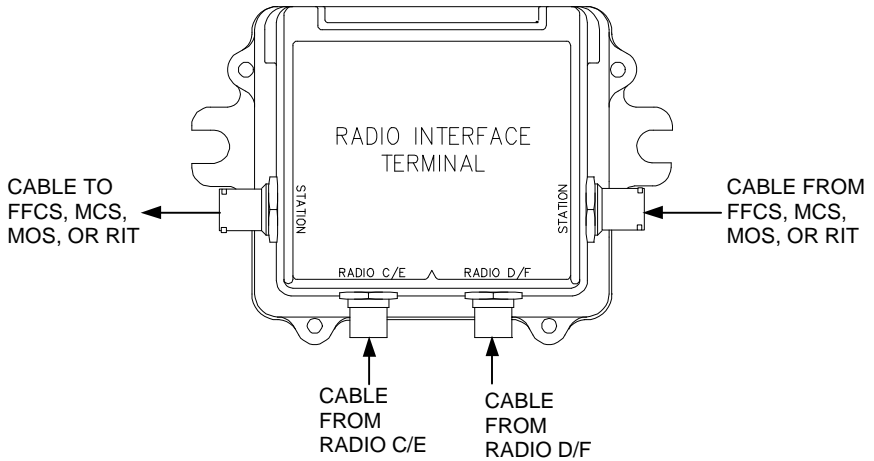

Figure 1-5. Radio Interface Terminal (RIT)

1.10.4 Monitor Only Station (MOS)

The MOS is a receive-only unit that allows personnel, such as infantry squad members, to be briefed over the intercom channel. The MOS receives and processes the audio signal through the highway cable. A loudspeaker (LS) may be attached to the HEADSET connector of the MOS for listen-only communication. The MOS unit allows independent control of audio volume level.

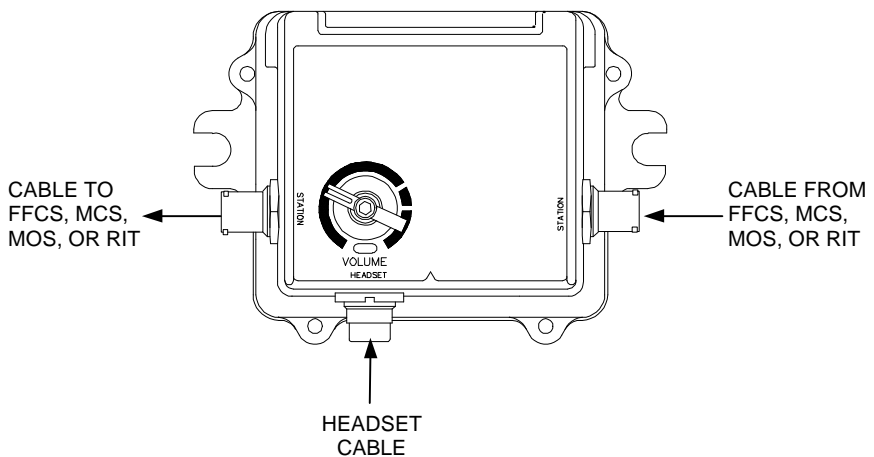

Figure 1-6. Monitor Only (Crew) Station (MOS)

1.10.5. Loudspeaker (LS)

The LS receives only analog audio and enables crewmembers, without headsets, to monitor intercom and/or radio traffic. It is normally connected to the MCS but may be connected to any crewstation (FFCS or MOS) in place of a headset. The LS, when utilizing a mounting bracket, is secured with a large wing nut. This allows quick removal from the bracket and unrestricted placement anywhere inside or outside the vehicle (within reach of the cord). The LS provides intelligible audio up to 50 feet from the vehicle.

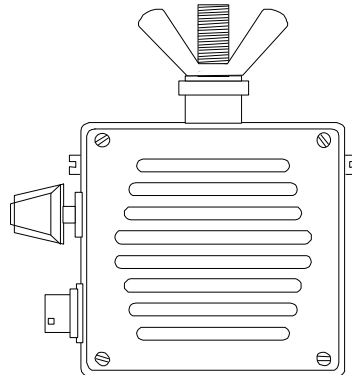

Figure 1-7. Loudspeaker (LS)

1.10.6. Headsets (CVC, PICVC, CAPS, ACAPS, and CCH)

These headsets employ similar features, such as Active Noise Reduction (ANR) and/or Passive Noise Reduction (PNR) to achieve noise reduction and enhance audibility. ANR is accomplished (when turned on) by electronic generation of noise canceling acoustic waves within each earcup. PNR is accomplished by soft conformal ear seals that are snug against the head and attenuate or reduce outside noise. All headsets are connected to the VIS system via a standard audio connector and quick-disconnect bailout connector to enable rapid disconnection from the system.

The Combat Vehicle Crewman's (CVC) headset consists of a Headset, Microphone installed in a liner. The liner comes in various sizes and contains fire-resistant fabric and bump-protection foam. It adjusts to fit individual heads by means of front and rear straps, with an adjustable chin strap to insure a tight fit for proper ANR operation. The electronic portion of the headset has two rigid, contoured, noise-attenuating earcups that fit into the liner and has a noise canceling microphone mounted on an adjustable boom off the right earcup. The left earcup has a three-position PTT switch mounted on the outside that is spring loaded to the center (disabled) position, with a momentary forward PTT position and a fixed rear live intercom position. In addition to PNR each earcup contains an independent ANR system controlled by an ANR/PNR switch mounted on the right earcup. The ANR system, which is activated when the switch is in the rear position, reduces background noise within each earcup. The PICVC headset has a provision for local communication when the headset is disconnected from the VIS to permit extra-vehicular communication. This provision is known as Talk Through Circuit (TTC), and when switched on, signals from microphones on front of the earcups are fed by battery powered electronics to speakers in the

corresponding earcup to produce stereo (i.e., directional) sound. TTC is activated by placing the ANR switch in the forward position.

The Communication Aural Protective System (CAPS) and Artillery Communication Aural Protective System (ACAPS) headsets employ the same PNR and/or ANR features utilized by the CVC headset. All headsets contain a three position switch for intercom (fixed position), radio (momentary position), and listen (center position) communications. Additionally, the ACAPS headset has a provision for the same TTC utilized by the PICVC headset. The Command and Control headset (CCH) does not utilize ANR and is used in quiet environments.

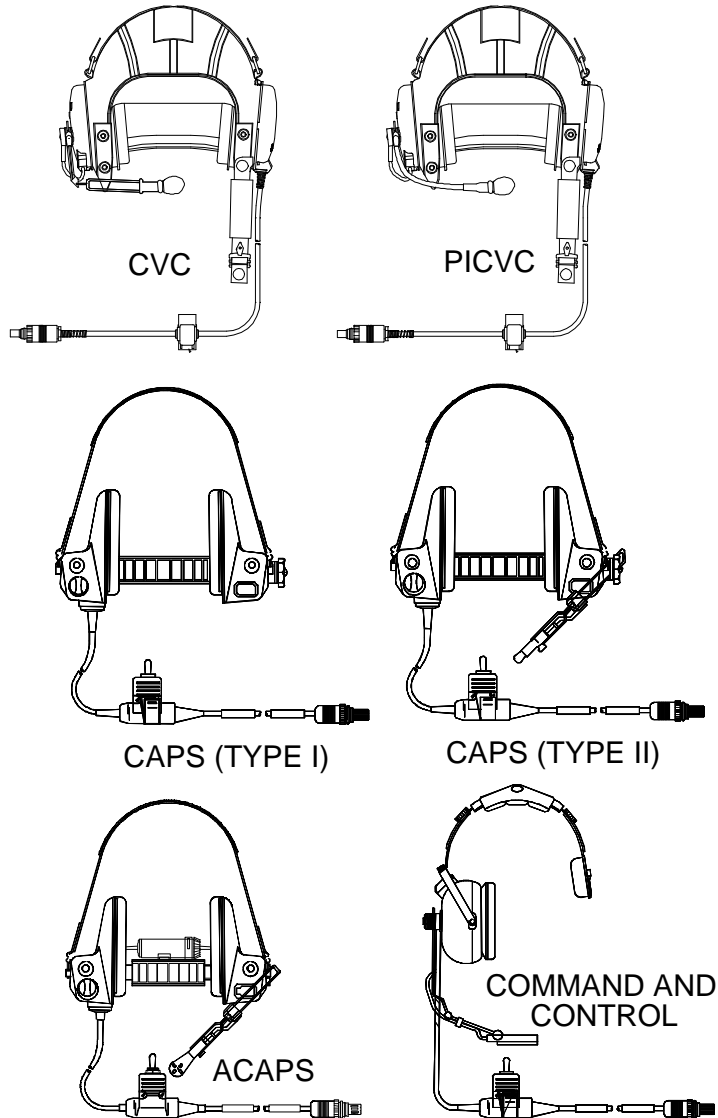

Figure 1-8. VIS Headsets

1.10.7. System Highway Bus

Within the interconnecting highway cables, VIS uses a two-wire bus for high frequency serial transmission of digital data for communication and control functions.

1.10.8. Built-In-Test (BIT)

Upon initial power-up of the MCS VIS automatically goes into (BIT) mode. This test mode monitors the digital interface of components of the system and the connect status of the interconnecting ring. Successful completion of BIT results with "pass" displayed on the MCS's alphanumeric display. If the MCS does not receive a valid response from a component in configuration memory, or receives an unexpected response, or does not confirm the connect status of the ring, the MCS displays "fail" and continually cycles through the configuration differences.

1.10.9. Continuous Performance Monitoring (CPM)

After BIT finishes, VIS goes into Continuous Performance Monitoring (CPM) mode. CPM monitors components of the system for normal operation. If any faults occur they are shown on the MCS alphanumeric display in code format.

1.10.10. Auto Reconnect Circuit (ARC)

An Auto Reconnect Circuit (ARC) provides the means of maintaining VIS operational capability in the event a major component or cable fails. Even in a case where there is a cut in a station-to-station VIS cable, the overall system continues to operate without degradation in performance. The system re-configures itself automatically by, 1). detecting the break, 2). automatically reconnecting any unconnected units, and 3). maintaining power to each unit. The ARC circuitry is so fast in reconnecting the data bus that its operation goes unnoticed, by the crew. To alert the crew that a problem occurred, the CPM flashes a ring unconnected "ru" .

1.11. EQUIPMENT DATA

PHYSICAL CHARACTERISTICS				
UNIT	HEIGHT (IN)	DEPTH (IN)	WIDTH (IN)	WEIGHT (LBS)
MCS	6.0	3.75	10.0	5.0
FFCS	4.5	3.5	4.75	1.9
RIT	4.5	3.5	4.75	2.1
MOS	4.5	3.5	4.75	1.4
LS	4.75	3.0	4.75	3.5

CHAPTER 2 OPERATING INSTRUCTIONS

	Page
SECTION I. Controls and Indicators	2-1
SECTION II. Operating Procedures, Under Normal Conditions.....	2-22
SECTION III. Operation Under Unusual Conditions.....	2-39

SECTION I. CONTROLS AND INDICATORS

2.1. SCOPE

This chapter provides operating information to crew members using the Vehicle Intercommunications System (VIS) equipment. It first provides information concerning the crew member controls available on the individual components of the system. It describes the controls, control settings and the resulting display for each setting as applicable. It provides information on the self-tests that are a built-in feature of the VIS. This chapter provides instructions for turning on the system, control settings by the commander, response control settings by crew members, and communications capability among stations and radios.

2.2. MCS: CONTROLS AND INDICATORS

2.2.1. CONNECTORS AND TERMINALS

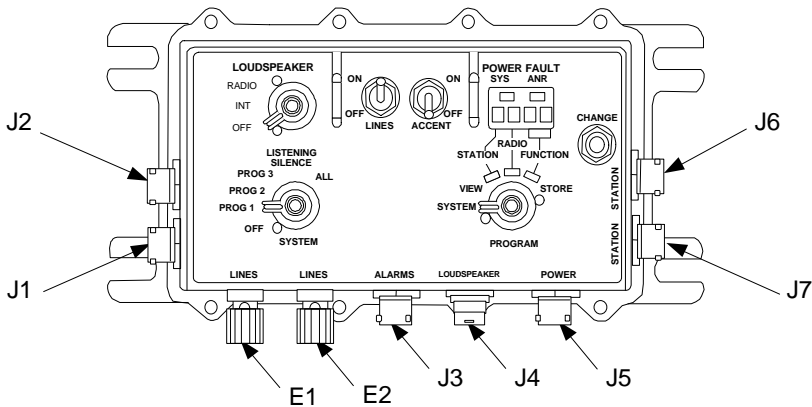

Figure 2-1. Master Control Station (MCS)

Table 2-1. MCS Connectors and Function

CONNECTOR/ TERMINAL REF DES	FUNCTION
STATION/J6	Highway cable connector; interface between MCS and all units in the system
STATION/J7	Highway cable connector; interface between MCS and all units in the system

MCS: CONTROLS AND INDICATORS - Continued

POWER/J5	Provides unregulated power to the MCS from the radio
LOUDSPEAKER /J4	Cable connector supplying audio signals to a loudspeaker
ALARMS/J3	Cable connector providing interface to incoming vehicle alarm signals
LINES/E1	Provides an interface for a twisted pair of wires used to connect the MCS to another MCS or a field telephone
LINES/E2	
RADIO B/J1	Cable connector interface to Radio B
RADIO A/J2	Cable connector interface to Radio A

2.2.2. SYSTEM SWITCH

The SYSTEM switch is used to select one of five MCS operating modes. The OFF position removes dc power, making the intercom system inoperable. Positions PROG 1, PROG 2, and PROG 3 define the level of access of each crewstation to the radios. The level of access is programmed into the MCS by the vehicle commander and/or crewmember. Position LISTENING SILENCE allows all connected crew stations to have receive only access to all radios. Position ALL allows connected crew stations to receive and transmit on all radios.

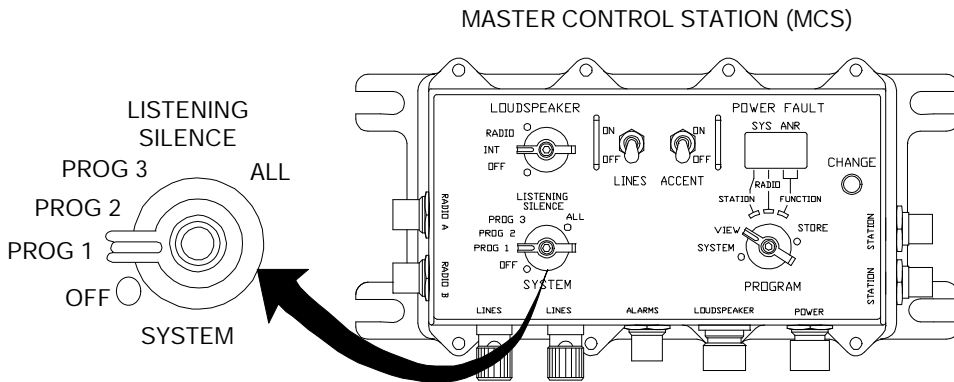

Figure 2- 2. SYSTEM Control Knob of MCS

Table 2-2. SYSTEM Switch Positions of MCS and Resulting Display

POSITION	FUNCTION	DISPLAY
OFF	Power is disconnected from all VIS units.	Blank
PROG 1	Allows access by crewstations to system radios as programmed by the commander/crewmember for this specific program setting.	P1

PROG 2	Allows access by crewstations to system radios as programmed by the commander/crewmember for this specific program setting.	P2
PROG 3	Allows access by crewstations to system radios as programmed by the commander/crewmember for this specific program setting.	P3
LISTENING SILENCE	Prevents crew members from transmitting on radios. All crewstations have receive only permission regardless of FFCS switch settings.	LS
ALL	Crew members have access to all on-board radio communications.	ALL

2.2.3. PROGRAM SWITCH

The PROGRAM switch is used in conjunction with the alphanumeric display. The PROGRAM switch, when used in conjunction with the SYSTEM and CHANGE switches, displays current operational status of crewstation radio access as well as permitting programming revision.

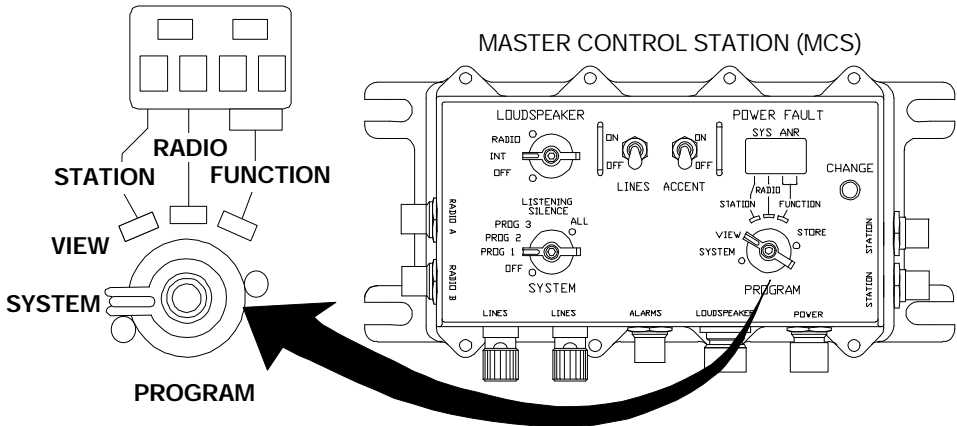



Figure 2-3. PROGRAM Control Knob of MCS

Table 2-3. Function and Resulting Display of PROGRAM Switch

SETTINGS	FUNCTION	DISPLAY
SYSTEM	Normal operation setting. On the alphanumeric display the selected setting of the SYSTEM switch (PROG1, etc.) is shown as well as any error messages caused by problems in the system.	P1, P2, P3, LS, ALL
VIEW	On the alphanumeric display the crewstation, radio, and level of access to the radio, as programmed in PROGs 1, 2, and 3 are shown.	various, e.g. 1Ar■
STATION	On the alphanumeric display the crewstation number is shown. Depressing the CHANGE switch allows scrolling through crewstations 1 to 6.	1, 2, 3, 4, 5, 6

MCS: CONTROLS AND INDICATORS - Continued

RADIO	On the alphanumeric display the radio designation is shown. Depressing the CHANGE switch allows scrolling through the radios A to F.	A, B, C, D, E, F
FUNCTION	On the alphanumeric display the level of access to each radio in the system, for each crewstation in the system is shown. Only three levels of access are defined and are as follows: a. No Access b. Receive Only c. Receive and Transmit	
STORE	This setting is a spring loaded switch. Holding this switch down, momentarily, stores what is shown on the alphanumeric display to the selected program (PROG 1, 2, or 3) that the SYSTEM switch is sent on.	various

2.2.4. CHANGE SWITCH

The CHANGE switch is used in conjunction with the SYSTEM and PROGRAM switches to do the following functions:

a. **CANCEL ERROR MESSAGES:** In normal operating mode with the SYSTEM switch set on PROG1, PROG2, or PROG3 and the PROGRAM switch set on SYSTEM, it can be used to cancel error messages (with the exception of ERR1, ERR2, & ERR3 messages) on the alphanumeric display. The condition causing the error message still exists but is no longer shown.

b. **ALTER BRIGHTNESS OF ALPHANUMERIC DISPLAY:** In normal operating mode with the SYSTEM switch set on PROG1, PROG2, or PROG3 and the PROGRAM switch set on SYSTEM, depressing the CHANGE switch changes the brightness level of the alphanumeric display. With each depression of the CHANGE switch, the brightness of the alphanumeric display goes from high brightness for daytime use (initial power-up of the MCS always starts at this brightness level), to low brightness for use with a darkened vehicle and night vision goggles, to shutting the display completely off, then back to high brightness.

c. **PROGRAMMING THE MCS:** When the SYSTEM switch is PROG1, PROG2, or PROG3, the CHANGE switch is used in conjunction with the PROGRAM SWITCH to define radio access levels of the crewstations. Depressing the CHANGE switch when the PROGRAM switch is set on STATION, RADIO, or FUNCTION allows the programmer to scroll through the crewstations available, radios available, and the function of receive and transmit, respectively.

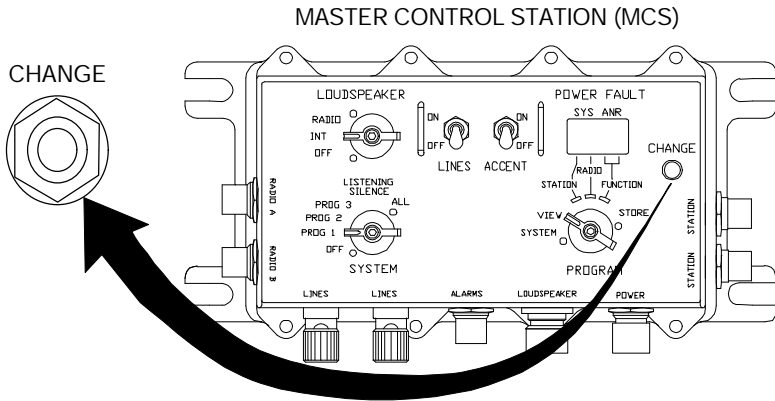

Figure 2- 4. CHANGE Switch of MCS

2.2.5. LOUDSPEAKER SWITCH

The LOUDSPEAKER switch in the INT position outputs audio received from the intercom channel. All communication from crew members from any crew station is output to the individual headsets as well as over the loudspeaker in this position.

In the RADIO position, the loudspeaker outputs audio received from all radios. The OFF position switches the loudspeaker OFF.

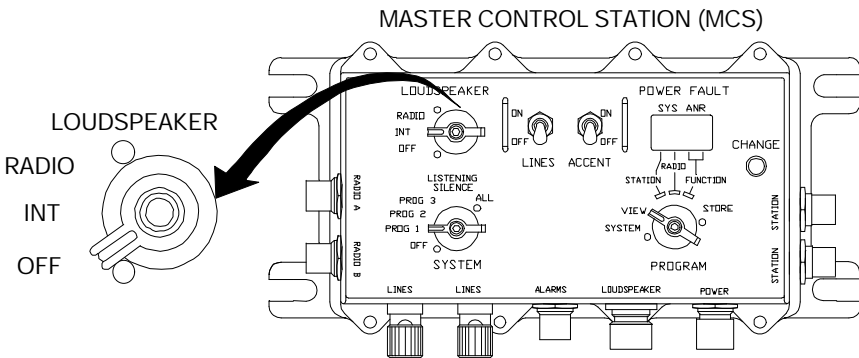

Figure 2-5. LOUDSPEAKER Control Knob of MCS

2.2.6. LINES SWITCH

The LINES switch in the OFF position disables the field wire transmit capability from the MCS but still allows reception. The LINES switch in the ON position permits field wire transmission and reception.

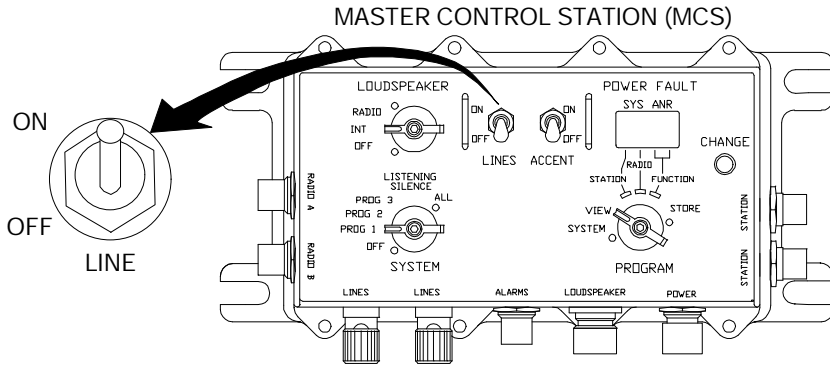

Figure 2-6. LINES Control Switch of MCS

2.2.7. ACCENT SWITCH

The ACCENT switch in the ON position reduces the volume of the radio signals by 20 dB and the vehicles alarm signal by 6 dB with respect to the intercom signal in order that the intercom is emphasized above all other signals; but only when an override condition occurs. In the OFF position all intercom, radio signals, and vehicle alarms remain at the same level.

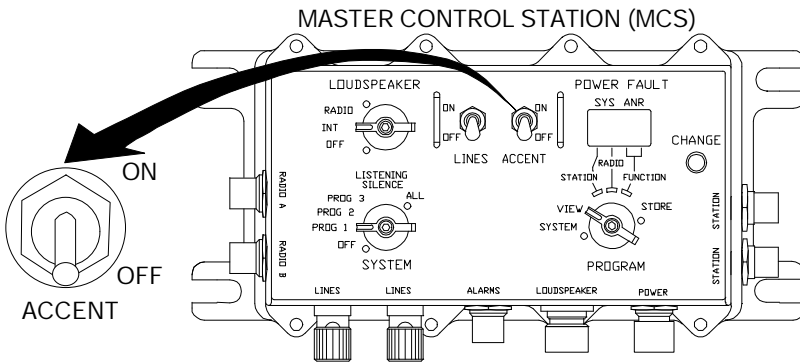

Figure 2-7. ACCENT Control Switch of MCS

MCS: CONTROLS AND INDICATORS - Continued

2.2.9. OPERATING CONTROLS OF THE MCS AT A GLANCE

Table 2-4. MCS Operating Control Switches and Function

SWITCH	POSITION	FUNCTION
SYSTEM	OFF	Power is disconnected from VIS.
	PROG 1, PROG 2, and PROG 3	Defines the level of access to each radio by the crewstations for each program.
	LISTENING SILENCE	All crewstations prevented from keying radios. Listen only.
	ALL	All FFCS's have full access to all radios.
PROGRAM	SYSTEM	Display shows what setting the SYSTEM switch is on or faults in the system.
	VIEW	Level of radio access for each crewstation as defined by PROG1, PROG2, or PROG3 is shown.
	STATION	Display highlights crewstation numbers as defined by PROG1, PROG2, or PROG3 by blinking. Depressing the CHANGE switch allows scrolling through crewstations 1 to 6.
	RADIO	Display highlights radio letters as defined by PROG1, PROG2, or PROG3 by blinking. Depressing the CHANGE switch allows scrolling through radios A to F.
	FUNCTION	Display highlights the level of access to radios as defined by PROG1, PROG2, or PROG3. Depressing the CHANGE switch allows no radio, receive only, or receive and transmit access.
	STORE	Rotating the spring-loaded switch momentarily to the STORE position stores what is shown on the display to PROG1, PROG2, or PROG3.

SWITCH	POSITION	FUNCTION
LOUDSPEAKER	OFF	No audio output.
	INT	Intercom audio is monitored.
	RADIO	All radio audio and override signals are monitored.
LINES	OFF	No outgoing intercom audio is placed on field phone line terminals. Ring tone is still received from incoming messages.
	ON	Two-way intercom audio is placed on LINES terminals.
ACCENT	OFF	Radio and intercom audio at same dB level.
	ON	Radio audio de-emphasized by 20 dB and vehicle alarm signal by 6 dB, with respect to intercom audio when an override signal is present.
CHANGE		Depressing the CHANGE switch, with respect to the settings of the SYSTEM and PROGRAM switches, allows changing display brightness levels, clearing of error messages (fault still exists until corrected) and programming functions.

2.3. FFCS: CONTROLS AND INDICATORS

WARNING

DISCONNECTING OR BYPASSING THE VEHICULAR INTERCOMMUNICATION SYSTEM (VIS) ALARM CABLE CONNECTED TO THE DRIVER'S FULL FUNCTION CREW STATION (FFCS) BY THE VEHICLE CREWMAN IS PROHIBITED. SUCH ACTION MAY RESULT IN INJURY OR DEATH. EQUIPMENT DAMAGE MAY ALSO RESULT. THIS CABLE ENABLES THE VEHICLE HAZARD WARNING TONES TO BE INSERTED DIRECTLY INTO THE INTERCOM SYSTEM, SO THAT THESE WARNING TONES CAN BE INSTANTLY HEARD BY ALL OF THE VEHICLE CREWMEMBERS. ONLY THE UNIT MAINTAINER IS AUTHORIZED TO REMOVE AND REPLACE THE ALARM CABLE. REFER TO THE APPROPRIATE VIS TECHNICAL PUBLICATIONS FOR OPERATOR, INSTALLATION, AND MAINTENANCE INSTRUCTIONS.

2.3.1. CONNECTORS

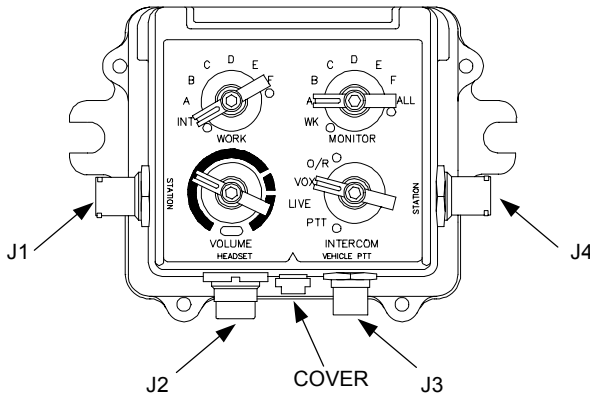

Figure 2-9. Connector Locations of FFCS

Table 2-5. FFCS Connectors and Function

CONNECTOR REF DES	FUNCTION
STATION/J1	Highway cable connector; interface between all units in the system.
HEADSET/J2	Connector interface between FFCS and a headset (via a Bailout Cable, or via an Alarm Cable and Bailout Cable), handset, or loudspeaker.
COVER/SWITCH	Cover protects screwdriver adjustable switch, which sets crew station address numbers.
VEHICLE PTT/J3	Cable connector allows for an external Push-To-Talk (PTT) switch.
STATION/J4	Highway cable connector; interface between all units in the system.

2.3.2. VOLUME CONTROL

The volume control is a rotary control that sets the volume of the audio heard through the headset or loudspeaker. The color bands around the volume control indicate the following volume levels, 85 dB (end of green), 95 dB (end of yellow), and 110 dB (end of red). There are click stops at these positions to prevent inadvertent adjustment due to vehicle or gun shock. Prolonged excess volume will lead to hearing loss.

WARNING

EXPOSURES TO RADIO SIGNALS IN THE FULL ON POSITION BEYOND 45 SECONDS MAY CAUSE HEARING LOSS. ANY PROLONGED EXPOSURE IN THE FULL ON VOLUME CONTROL SETTING REQUIRES THE USE OF A SINGLE HEARING PROTECTIVE DEVICE IN EACH EAR.

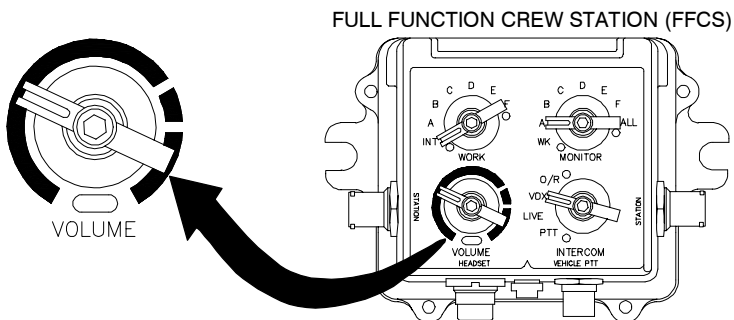

Figure 2-10. VOLUME Control of FFCS

2.3.3. WORK SWITCH

The WORK switch, when placed in the INT position, permits the crew member access to the intercom channel. In positions A, B, C, D, E, and F if access is permitted, the crew member can communicate over the selected radio by use of the momentary PTT switch.

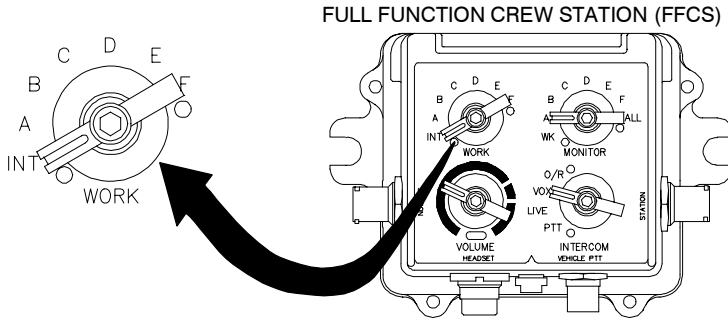

Figure 2-11. WORK Control Switch of FFCS

2.3.4. MONITOR SWITCH

The MONITOR switch, when placed in the WK position, permits the crew member access to the functions selected on the WORK switch. In positions A, B, C, D, E, and F the crew member can monitor one radio (MONITOR switch) while transmitting and receiving on another radio (WORK switch). In the ALL position the crew member can receive all radio channels as defined by the programming of the MCS.

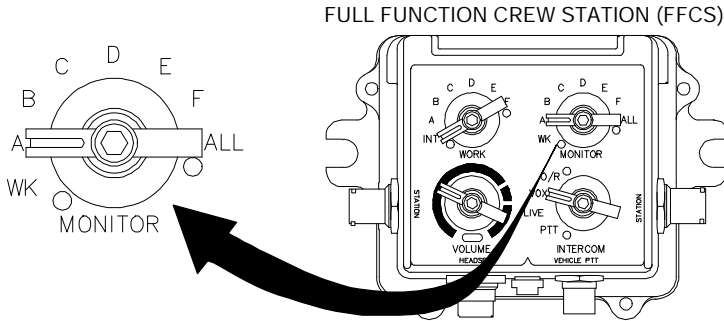

Figure 2-12. MONITOR Control Switch of FFCS

2.3.5. INTERCOM SWITCH

The INTERCOM switch allows two-way communication over the radios only (subject to the access levels defined in PROG 1, PROG 2, and PROG 3), intercom only, or radios and intercom.

When placed in the push-to-talk (PTT) position the crewmember must activate the headset or vehicle PTT switch in order to engage in two-way intercom communication, if the WORK switch is in the INT position, or two-way radio communication, if the WORK switch is in the A-F position

When placed in the LIVE position, the crewmember can communicate over the intercom hands free regardless of the position of the work switch. Two-way radio communication is still subject to the WORK switch settings of A-F and activation of the headset or vehicle PTT switch.

When placed in the VOX (Voice Operated Switch) position the crewmember can communicate on the intercom hands free but without introducing vehicle noise as long as the volume of the signal is sufficient to overcome the threshold level setting of the VOX. Two-way radio communication is still subject to the WORK switch settings of A-F and activation of the headset or vehicle PTT switch.

The O/R (override) position allows a crewmember's communication to take priority over any traffic on the intercom channel no matter what other crewstation FFCSs are set on. The O/R position is a momentary position, therefore the INTERCOM switch must be held in this position for the duration of the communication. When the switch is released it returns to the VOX position.

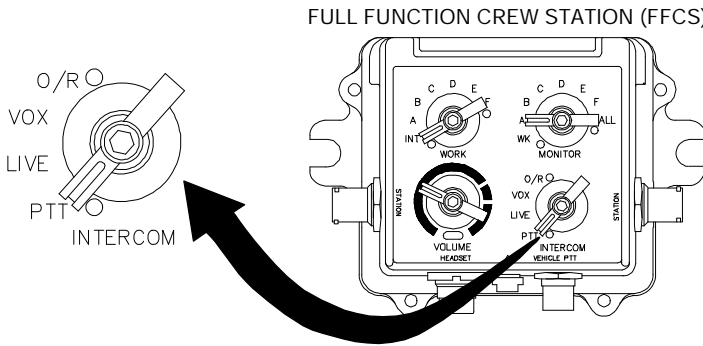

Figure 2-13. INTERCOM Control Switch of FFCS

The following tables demonstrate one or two-way communication scenarios utilizing headset PTT switches when the crewstation FFCS INTERCOM switch is set on PTT, LIVE, VOX or O/R and the FFCS WORK and MONITOR switches have various combinations of settings.

Table 2-6. PTT INTERCOM Switch Settings of FFCS

FFCS WORK SWITCH	FFCS MONITOR SWITCH	HEADSET PTT SWITCH	TYPE OF COMMUNICATION
INT	WK	OFF (center)	Receive intercom
		ON (fixed)	Transmit/receive intercom
		ON (momentary)	Transmit/receive intercom
	A-F	OFF (center)	Receive intercom and receive selected radio*
		ON (fixed)	Transmit/receive intercom and receive selected radio*
		ON (momentary)	Transmit/receive intercom
	ALL	OFF (center)	Receive intercom and receive all programmed radios*
		ON (fixed)	Transmit/receive intercom and receive all programmed radios*
		ON (momentary)	Transmit/receive intercom
A-F	WK	OFF (center)	Receive intercom and receive selected radio*
		ON (fixed)	Transmit/receive intercom and receive selected radio*
		ON (momentary)	Transmit on selected radio*
	A-F	OFF (center)	Receive (2) selected radios*
		ON (fixed)	Transmit/receive intercom and receive (2) selected radio(s)*
		ON (momentary)	Transmit on selected radio*
	ALL	OFF (center)	Receive all programmed radios*
		ON (fixed)	Transmit/receive intercom and receive all programmed radios*
		ON (momentary)	Transmit on selected radio*

* If permitted

Table 2-7. LIVE and VOX INTERCOM Switch Settings of FFCS

FFCS WORK SWITCH	FFCS MONITOR SWITCH	HEADSET PTT SWITCH	TYPE OF COMMUNICATION
INT	WK	OFF (center)	Transmit/receive intercom
		ON (fixed)	Transmit/receive intercom
		ON (momentary)	Transmit/receive intercom
	A-F	OFF (center)	Transmit/receive intercom and selected radio*
		ON (fixed)	Transmit/receive intercom and receive selected radio*
		ON (momentary)	Transmit/receive intercom
	ALL	OFF (center)	Transmit/receive intercom and all programmed radios*
		ON (fixed)	Transmit/receive intercom and all programmed radios*
		ON (momentary)	Transmit/receive intercom
A-F	WK	OFF (center)	Transmit/receive intercom and receive selected radio*
		ON (fixed)	Transmit/receive intercom and receive selected radio*
		ON (momentary)	Transmit on selected radio*
	A-F	OFF (center)	Transmit/receive intercom and receive (2) selected radios*
		ON (fixed)	Transmit/receive intercom and receive selected radio(s)*
		ON (momentary)	Transmit on selected radio*
	ALL	OFF (center)	Transmit/receive all programmed radios*
		ON (fixed)	Transmit/receive intercom and receive all programmed radios*
		ON (momentary)	Transmit on selected radio*

* If permitted

Table 2-8. O/R INTERCOM Switch Setting of FFCS

FFCS WORK SWITCH	FFCS MONITOR SWITCH	TYPE OF COMMUNICATION
Any setting	Any setting	In this setting, signals are received based on MCS programming from the selected radio(s), however the transmitted intercom override signal is received by all other crew members. When the ACCENT switch on the MCS is set to ON, this override intercom signal is emphasized above the level of any radio signals being received.

2.4. MOS: CONTROLS AND INDICATORS.

2.4.1. CONNECTORS

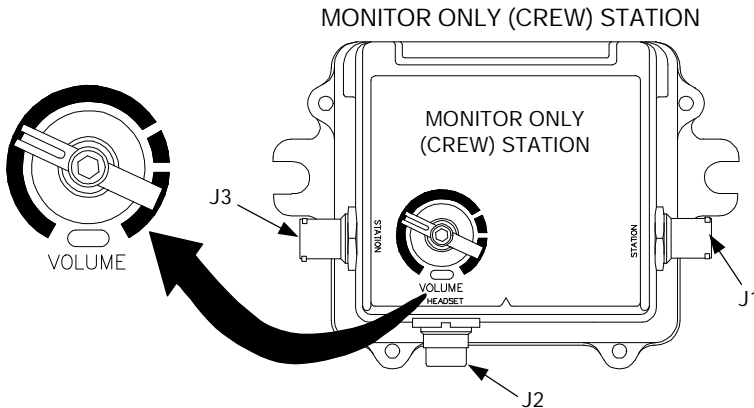

Figure 2-14. VOLUME Control of MOS

Table 2-9. MOS Connectors and Function

CONNECTOR/ TERMINAL REF DES	FUNCTION
STATION/J1	Highway cable connector; interface between all units in the system
HEADSET/J2	Cable connector which provides interface to a headset or loudspeaker
STATION/J3	Highway cable connector; interface between all units in the system

2.4.2. VOLUME CONTROL

The volume control is a rotary control that sets the volume of the audio heard through the headset or loudspeaker. To reduce volume, crew member turns control in a counter-clockwise direction and for increased volume, in a clockwise direction. The color bands around the volume control indicate the following volume levels, 85 dB (end of green), 95 dB (end of yellow), and 110 dB (end of red). There are click stops at these positions to prevent inadvertent adjustment due to vehicle or gun shock. Volume levels at the headset receiver must be adjusted to the minimum levels required for operation. The volume control should be adjusted from the minimum position in the green click stop zone, up to a comfortable level. Prolonged excess volume will lead to hearing loss.

WARNING

EXPOSURES TO RADIO SIGNALS IN THE FULL ON POSITION BEYOND 45 SECONDS MAY CAUSE HEARING LOSS. ANY PROLONGED EXPOSURE IN THE FULL ON VOLUME CONTROL SETTING REQUIRES THE USE OF A SINGLE HEARING PROTECTIVE DEVICE IN EACH EAR.

2.5. RIT: CONTROLS AND INDICATORS.

2.5.1. CONNECTORS

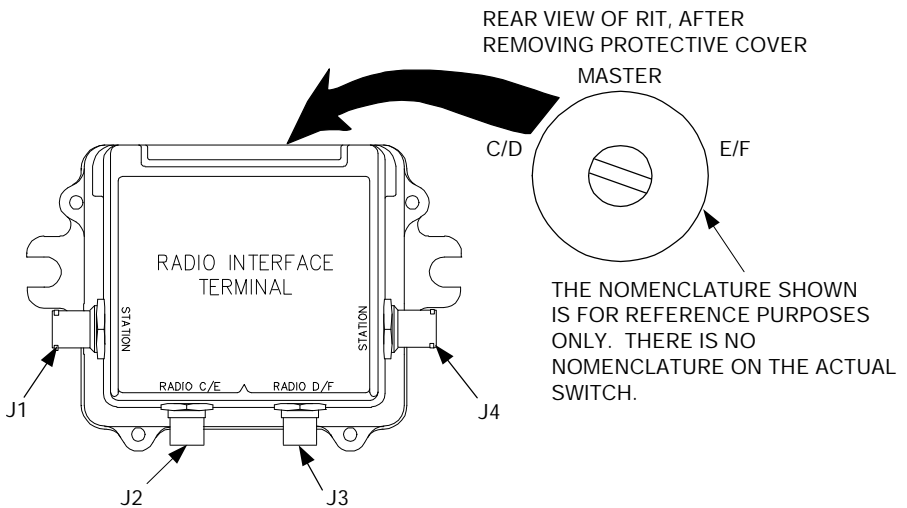

Figure 2-15. Radio Interface Terminal (RIT)

Table 2-10. RIT Connectors and Functions

CONNECTOR/ TERMINAL REF DES	FUNCTION
STATION/J1	Highway cable connector; interface between radios and MCS, MOSs, and FFCSs.
RADIO C/E J2	Cable connector which provides an interface to Radio C or Radio E.
RADIO D/F J3	Cable connector which provides an interface to Radio D or Radio F.
STATION/J4	Highway cable connector; interface between radios and MCS, MOSs, and FFCSs.
COVER/ SWITCH	Cover protects screwdriver adjustable switch, which sets RIT radio(s) identification letters.

2.5.2. CONTROLS

There are no crew member controls, adjustments, indicators, or displays on this unit.

2.6. LOUDSPEAKER ASSEMBLY.

2.6.1. LOUDSPEAKER ASSEMBLY WITH VOLUME CONTROL

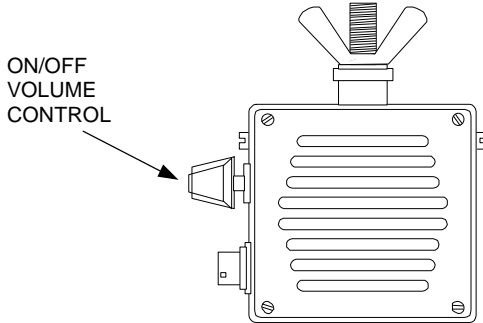

Figure 2-16. Loudspeaker (LS) Assembly with Volume Control

Table 2-11. LS Assembly and Functions

CONNECTOR/ TERMINAL REF DES	FUNCTION
P1	Uses audio cable with connector that interfaces with an MCS, FFCS or MOS. (LS Assembly does not include audio cable.)
On/Off Volume Control	On/Off/Volume control adjusts volume of communication heard through loudspeaker.

2.7. CVC HEADSET CONNECTORS AND CONTROLS

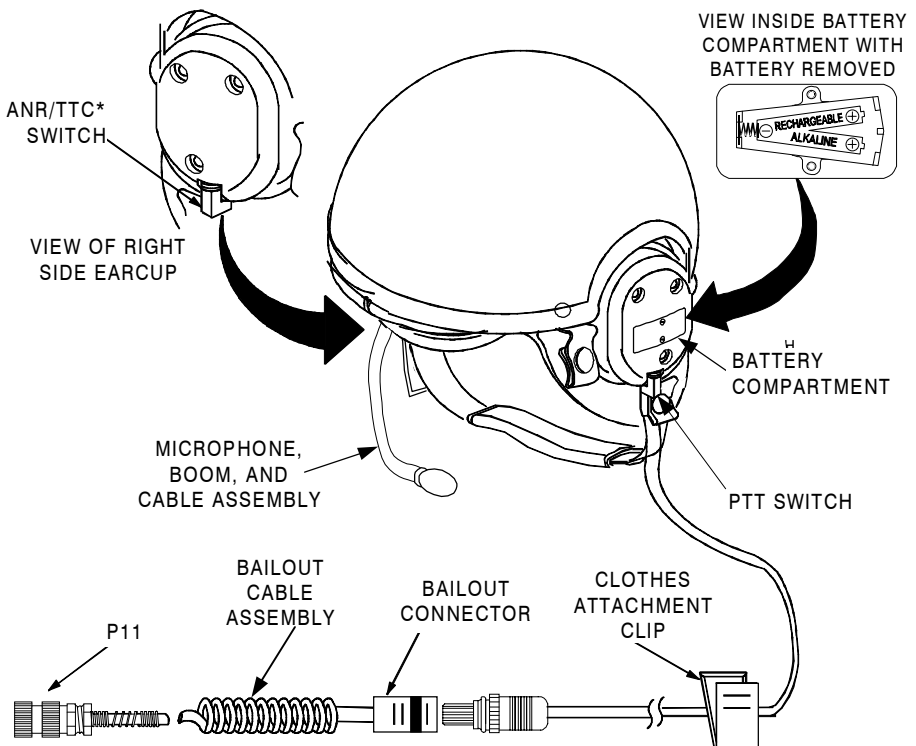

Figure 2-17. CVC Headset Major Components

NOTE

During vehicle operation tank crewmen are only authorized to disconnect the drop cord [attached to the left ear cup of the Combat Vehicle Crewman (CVC) Headset] from the Bailout Cable Assembly (Spaghetti Cord). This cable is connected directly to the VIS FFCS or Driver Alarm Cable. No other VIS cables may be removed/bypassed/replaced by the crewman. During PMCS only the Bailout Cable Assembly may be disconnected from the FFCS or Alarm Cable for cleaning and application of silicone gel to the connector O-ring. Upon completion of PMCS the Bailout Cable Assembly(s) should immediately be re-connected. Refer to the VIS Operator's Manual for instructions. All other maintenance should be referred to the Unit Maintainer.

Table 2-12. CVC Headset Major Components and Function

COMPONENT	FUNCTION
Microphone, Boom, and Cable Assembly	Inputs crew member audio communication into intercom or radio channel.
PTT switch (left earcup)	Used when transmitting on intercom channel (rear - fixed position) or radio (forward - momentary position). Center position is used to listen to intercom and/or radio.
Clothes Attachment clip	Used to dress headset cable out of way to prevent entanglement or interference.
Bailout Cable Assembly	Bailout connector provides quick-disconnect for crew member. Standard audio cable connector, P11, interfaces headset with an FFCS, MOS or an Alarm Cable. (Bailout Cable Assembly is not a component of CVC.)
ANR/TTC switch (right earcup)	Used to reduce vehicle noise heard by the crewman (Rear Position). TTC is used for extra vehicular communication (Forward Position). *Older model CVC's do not have TTC capability.
Battery Compartment	Contains rechargeable AA Nickel Metal Hydride or AA Alkaline battery to power TTC circuit.

2.8. CAPS, ACAPS, AND CCH HEADSETS.

2.8.1. CONNECTORS AND CONTROLS

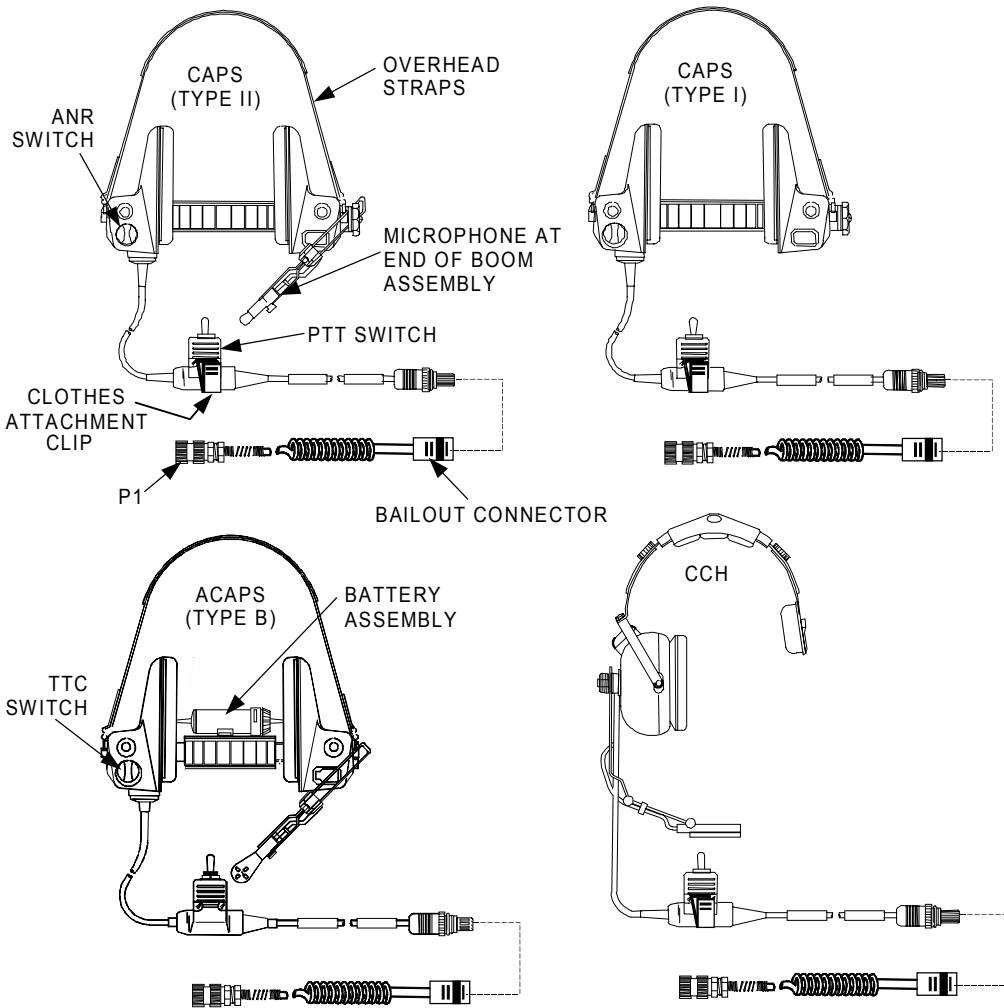

Figure 2-18. CAPS, ACAPS, and CCH Headsets Major Components

Table 2-13. CAPS, ACAPS, and CCH Headsets Major Components and Function

COMPONENT	FUNCTION
Microphone	Inputs crew member audio communication into intercom or radio channel.
PTT switch	Used when transmitting on intercom channel (fixed position) or radio (momentary position). Center position is used to listen to intercom and/or radio.

Attachment clip	Used to dress headset cable out of way to prevent entanglement or interference.
Bailout connector	Provides quick-disconnect for crew member.
P1	Standard audio cable connector interfaces headset with an FFCS or MOS.
ANR switch	Used to reduce vehicle noise heard by the crewman.
TTC switch	In the Talk Through Circuit (TTC) position, two or more crewmen can talk to each other, up to 15 feet apart, while outside the vehicle and disconnected from their crewstations.
Battery Assembly	Provides power for the Talk Through Circuit (TTC).

SECTION II. OPERATING PROCEDURES UNDER NORMAL CONDITIONS

2.9. VIS OPERATION

2.9.1 MCS Operation for Radio and Intercom Functions

NOTE

For demonstrating VIS operational procedures PROG 1 is utilized as an example. Procedures outlined for PROG 1 below also apply to PROG 2, PROG3, LS (Listening Silence) and ALL program modes except the display will change according.

a. Initial operation of the VIS begins upon power-up of the MCS (via the vehicle power through the radios/radio mount) by:

- 1) Setting the PROGRAM switch on SYSTEM
- 2) Setting the SYSTEM switch on PROG 1

b. The display will show while the system is initializing.

c. Programming information (for programming procedures refer to paragraph 2.10) is transmitted to the radio interfaces and FFCSs.

d. The Built-In-Test (BIT) starts; the display will show t e s t. The BIT, in addition to checking the system configuration for system and ANR power, performs three functions in the following order:

1. Power-On Poll - where each, crewstation (FFCS), as well as radios A through F, are polled to determine their status (connected or disconnected/defective), in other words, the MCS is seeing what's out there.

2. EEPROM Test - where the MCS tests the read/write capability of its memory by storing and retrieving test data from the EEPROM RAM. If the MCS cannot store radio access data in its program memory error messages "err1, err2, or err3" are displayed. These error messages cannot be cleared from the display by pressing the CHANGE button.

3. Configuration Test - where the MCS compares the connect status of the crewstations and radio(s) that have been programmed into memory via the system configuration procedures (refer to para. 2.10.1) with the connect status as determined by the Power-On Poll.

e. If there are no configuration discrepancies or errors, the display shows

p a s s followed immediately by the system mode P 1

f. If there are configuration discrepancies or errors, the display will show **f a i l** ; followed by error codes which determine the crew stations or radio interfaces that are unconnected (or are faulty). Refer to Paragraph 2.12.

g. The display will continue to show any configuration discrepancies and/or errors unless the user presses the CHANGE switch, which will clear the error message but not the fault.

h. After the display shows **p a s s** followed by **P 1** the system is now ready for normal communications operation.

i. Crew members may now establish communication within their programmed capabilities.

j. The procedure for system modes PROG 2, PROG 3, LISTENING SILENCE, and ALL modes is the same as steps a. through h. above, except the display of the mode will change accordingly.

2.9.2. Viewing Radio Access Levels For P1, P2, and P3.

NOTE

VIEW mode by the PROGRAM switch is not available when the MCS SYSTEM mode switch is in the LISTENING SILENCE or ALL position.

a. Select the VIEW position on the PROGRAM switch of the MCS. The display will show **v i e w** and will then commence scrolling through the radio access levels for each connected crew station.

Table 2-14. MCS VIEW Position Display Examples	
Display	Meaning
1 -	No access to any radios at crew station 1
2 A r	Receive only access to radio A at crew station 2
3 r t	Receive and Transmit access to all radios at crew station 3
6 D r t	Receive and Transmit access to radio D at crew station 6

b. Only those radios programmed for access by a crew station are displayed.

2.10. MCS PROGRAMMING PROCEDURES

Paragraphs 2.10.1 and 2.10.2 take a step-by-step approach to the proper way to program the MCS when a) it is initially installed, and b) making changes/ corrections to the existing program in the MCS. Additionally, various capabilities of the MCS will be explained which will provide a better understanding of the VIS equipment which will assist in making programming decisions and corrections.

NOTE

It is necessary to make a few assumptions prior to initial programming or corrections:

a. That all FFCSs have the proper setting (1,2,3,4,5 or 6).

TM 11-5830-263-10

- b. That all RITs have the proper setting (c/d, e/f).
- c. That all cabling is routed and connected properly.

Any deviations from the proper settings and connections may result in error messages being displayed on the MCS. FFCS and RIT settings are not operator level tasks and are covered in TM 11-5830-263-20&P. Refer to higher level maintenance for the proper FFCS and RIT settings or if error messages are displayed.

2.10.1. Initial Programming of the MCS

To initially program the MCS we are looking at a system containing 1 MCS, 4 FFCSs, and 1 RIT. MOSs and Loudspeakers do not register on the MCS and therefore do not require programming. For the programming procedures described below the following parameters are defined:

DESIRED FUNCTION	MEANING
1Ar	FFCS 1, Radio A, Receive only
2Ar	FFCS 2, Radio A, Receive and Transmit
3Art,3Brt	FFCS 3, Radio A and B, Receive and Transmit
4Art,4Crt	FFCS 4, Radio A and C, Receive and Transmit

a. SETTING THE SYSTEM CONFIGURATION

1. On the MCS, set and hold the PROGRAM switch in the STORE position.
2. While holding the PROGRAM switch in the STORE position depress and hold the CHANGE button.
3. While holding the PROGRAM switch in the STORE position and depressing the CHANGE button, set the SYSTEM switch in the ALL position. Observe the display as it cycles through *** * * ***, **P r 1 5**, **v 0 7** and **c f i g**. When **c f i g** appears on the display release the PROGRAM switch and CHANGE button.

NOTE

To learn the configuration of the system the SYSTEM switch can also be placed on PROG 1, PROG 2, or PROG 3, while doing the System Configuration procedures. On vehicles which do not have a ring configuration, but rather a two branch, the system configuration procedures prevent the "ru" error message from appearing.

The display will then show the system configuration, e.g. what FFCSs (1,2, 3,4,5,6) and RITs (c/d, e/f) are connected as well as if the ring is connected.

TM 11-5830-263-10

b. Set PROGRAM switch to FUNCTION. Depress CHANGE button until display shows **2 Art**.

c. Turn PROGRAM switch to the STORE position momentarily and release. **2 Art** is stored to program memory.

3. Programming **3Art** and **3Brt** to memory.

a. Set PROGRAM switch to STATION. Display shows **2 Art**. Depress CHANGE button until 2 changes to 3. Display will show **3 A * ***.

b. Set PROGRAM switch to FUNCTION. Depress CHANGE button until display shows **3 Art**.

c. Turn PROGRAM switch to the STORE position momentarily and release. **3 Art** is stored to program memory.

d. Set PROGRAM switch to RADIO. Display shows **3 Art**. Depress CHANGE button until A changes to B. Display will show **3 B * ***.

e. Set PROGRAM switch to FUNCTION. Depress CHANGE button until display shows **3 Brt**.

f. Turn PROGRAM switch to the STORE position momentarily and release. **3 Brt** is stored to program memory.

4. Programming **4Art** and **4Crt** to memory.

NOTE

Programming radio access levels to crewstations need not be done in any particular order. **4Crt** is stored to program memory before **4Art** in the steps below.

a. Set PROGRAM switch to STATION. Display shows **3 Brt**. Depress CHANGE button until 3 changes to 4. Display will show **4 B * ***.

b. Set PROGRAM switch to RADIO. Depress CHANGE button until B changes to C. Display will show **4 C * ***.

c. Set PROGRAM switch to FUNCTION. Depress CHANGE button until display shows **4 Crt**.

d. Turn PROGRAM switch to the STORE position momentarily and release. **4 Crt** is stored to program memory.

e. Set PROGRAM switch to RADIO. Display shows **4****C****r****t**.
 Depress CHANGE button until C changes to A (display will scroll through D, E, F then A). Display will show **4****A************.

f. Set PROGRAM switch to FUNCTION. Depress CHANGE button until display shows **4****A****r****t**.

i. Turn PROGRAM switch to the STORE position momentarily and release. **4****A****r****t** is stored to program memory.

c. VERIFYING PROGRAMMING INFORMATION

NOTE

Utilizing the VIEW mode on the PROGRAM switch enables the programmer/operator to verify the level of radio access for each crewstation/FFCS for the selected program (PROG 1, PROG 2, PROG 3). Though the same function can be accomplished utilizing the CHANGE button while alternately setting the PROGRAM switch on STATION and RADIO the VIEW mode is quicker and not subject to operator error.

1. Set PROGRAM switch to VIEW and observe display. If programming has been correctly accomplished the display should show in sequence

P**1****□****□**, **v****i****e****w**, **1****A****r*******, **2****A****r****t**, **3****A****r****t**,
3**B****r****t**, **4****A****r****t**, **4****C****r****t**.

2. If programming is correct set PROGRAM switch on SYSTEM and begin communication operations.

3. If programming is incorrect refer to para 2.10.2. to make changes to existing programming.

4. If error messages occur upon placing the PROGRAM switch in the SYSTEM position refer to the troubleshooting chart in Chapter 3 or higher level maintenance.

2.10.2 Changes To Existing Programming

Making changes to existing programming involve the same procedures demonstrated for programming the MCS (refer to para. 2.10.1(b)). The SYSTEM switch is set on the specific program requiring change (PROG 1, PROG 2, PROG 3), while the PROGRAM switch is set on STATION/RADIO/FUNCTION and used in conjunction with the CHANGE button. Figure 2-19 shows the procedures required when making a change to the programming accomplished in para. 2.10.1(b) where FFCS 2 is adding the capability to receive and transmit on radio B (current capability shows FFCS 2 receiving and transmitting on radio A only).

TM 11-5830-263-10

THE FOLLOWING SEQUENCE SHOWS HOW THE COMMANDER WOULD PROGRAM FFCS NO. 2 TO HAVE RECEIVE AND TRANSMIT ACCESS ON RADIO B. THE DISPLAY ALWAYS SHOWS THE CURRENT PROGRAM FOR EACH FFCS AND RADIO WHEN CYCLING WITH THE CHANGE SWITCH.

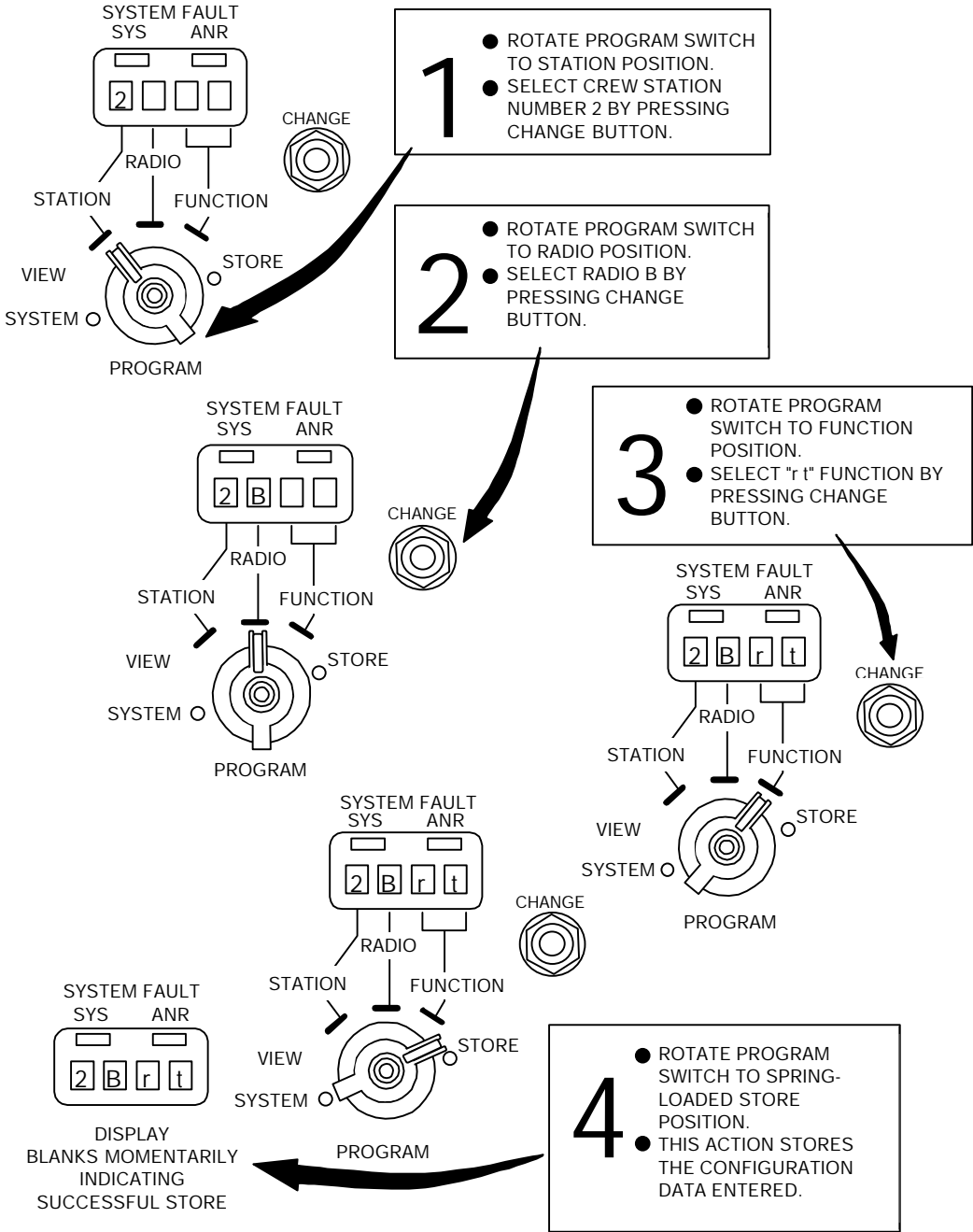

Figure 2-19 Changing Existing Programming

2.11. REMOTE FFCS OPERATION

Provision is made in some VIS versions for temporary installation and use of a FFCS outside the vehicle, for example a S-787 SICPS platform (see figure 2-20). Refer to the procedures in paragraphs 2.11.1. and 2.11.2. for installation and removal of this particular version.

NOTE

For clarity purposes the vehicle used for remote FFCS operation contains four internal FFCSs, designated with crewstation settings of 1, 2, 3 and 4, and one remote FFCS, designated with a crewstation setting of 5.

When operating the VIS in a vehicle that utilizes a remote FFCS two approaches can be utilized:

a. **Configure the vehicle with the remote FFCS installed**, then remove it from the ring configuration and proceed with normal operations. To utilize this approach do the following procedures:

NOTE

When disconnecting or connecting cables for removing and replacing remote FFCSs the MCS should be turned off.

1. Install the remote FFCS (refer to para. 2.11.1).
2. Do the System Configuration procedures (refer to para. 2.10.1(a)).
3. Program all 5 FFCSs with the desired radio access levels (refer to para.2.10.1(b)).
4. Remove the remote FFCS (refer to para. 2.11.2).
5. Turn the MCS back on for normal VIS operation (SYSTEM switch set on PROG 1 and PROGRAM switch set on SYSTEM).

When BIT is initiated, upon powering-up of the MCS, the alphanumeric display will show in order **TEST, FAIL, 5u**. This results because the Power-On Poll sees FFCSs 1, 2, 3, and 4, as connected, but is being compared to the System Configuration memory which shows FFCSs 1, 2, 3, 4, and 5 as connected. This condition does not effect VIS operation and depressing the CHANGE button will remove this error message (but not the condition) from the display.

b. **Configure, the vehicle with only the internal FFCSs, then reconfigure every time a remote FFCS is installed then removed.** To utilize this approach do the following procedures:

1. Do the System Configuration procedures (refer to

TM 11-5830-263-10

para. 2.10.1(a)).

2. Program all 5 FFCS (refer to the paragraph following Step 6 below for explanation) with the desired radio access levels (refer to para. 2.10.1(b)).
3. Install the remote FFCS (refer to para. 2.11.1).
4. Repeat Step 1 above and operate system as configured.
5. Remove the remote FFCS (refer to para. 2.11.2).
6. Repeat Step 1 above and operate system as configured.

Radio access for non-existent FFCSs, e. g. 6 FFCSs are programmed but only 4/5 are utilized in the system, can be programmed into the MCS which will generate a TEST, PASS when BIT is preformed. Additionally, you can actually program the MCS for radio access levels for each FFCS prior to performing the System Configuration procedures with no effect on operation, but error messages will be displayed.

Utilizing approach b can result in the overlooking of reconfiguring the system everytime the remote FFCS is installed or removed. If this does happen normal VIS operation will not be affected but will result in the following scenarios:

ALPHANUMERIC DISPLAY SHOWS AFTER BIT	PROBABLE CAUSE	REASON	CORRECTIVE ACTION
TEST, FAIL, 5C	REMOTE FFCS WAS INSTALLED WITHOUT RE-CONFIGURING	POLL-ON TEST SEES 5 FFCSs (1, 2, 3, 4, 5) CONNECTED BUT IS COMPARED TO THE SYSTEM CONFIGURATION MEMORY WITH ONLY 4 FFCSs (1, 2, 3, 4) CONFIGURED	1. DEPRESS THE CHANGE BUT-TON TO REMOVE THE ERROR MESSAGE (BUT NOT THE CONDI-TION) FROM THE DISPLAY. OR
TEST, FAIL, 5U	REMOTE FFCS WAS REMOVED WITHOUT RE-CONFIGURING	POLL-ON TEST SEES 4 FFCSs (1, 2, 3, 4) CONNECTED BUT IS COMPARED TO THE SYSTEM CONFIGURATION MEMORY WITH 5 FFCSs (1, 2, 3, 4, 5) CONFIGURED	2. DO THE SYSTEM CONFIGURATION PROCEDURES (REFER TO PARA 2.10.1(A))

2.12. RESPONSE TO ERROR MESSAGES

Error messages are shown on the alphanumeric display. In many cases error messages indicate problems that do not necessarily interfere with communications. With the exception of error messages “err1, err2, and err3”, which indicate problems with the actual memory program and require higher level maintenance, all error messages can be cleared from the display by depressing the CHANGE button. This does not correct the problem, it only clears the error message(s) from flashing on the display. Prior to any action taken to correct the problem, the condition on the display should be noted, then the MCS cycled to OFF, then back to the appropriate program, PROG 1, PROG 2, or PROG 3. If the condition remains operator troubleshooting (refer to Chapter 3) should be accomplished. If the condition still exists after operator troubleshooting then refer to higher level maintenance.

2.13. COMMUNICATING FROM AN FFCS

A crewmember wearing a headset connected to an FFCS has the ability to transmit and receive on a selected radio and/or intercom (WORK switch), while monitoring 1 additional or all on-board radio(s) (MONITOR switch), subject to the radio access levels programmed into the MCS. Additionally, the FFCS allows the capability to select transmission modes as determined by the INTERCOM switch. The positioning of the headset or vehicle PTT switches can also determine transmission modes. The table below shows various switch setting combinations provided by the FFCS.

CAPABILITIES PROVIDED BY FFCS		SWITCH SETTINGS		
RECEIVE & XMIT ON	ALSO MONITOR	WORK SW	MONITOR SW	INTERCOM SW
INTERCOM	-----	INTERCOM	WORK	VOX, LIVE, PTT
INTERCOM	ONE RADIO	INTERCOM	A-F	VOX, LIVE, PTT
INTERCOM	ALL RADIOS	INTERCOM	ALL	VOX, LIVE, PTT
RADIO*	-----	A-F	WORK	PTT
RADIO*	ONE RADIO	A-F ≠	A-F	PTT
RADIO*	ALL RADIOS	A-F	ALL	PTT
RADIO & INTERCOM	-----	A-F	WORK	VOX, LIVE
RADIO & INTERCOM	ONE RADIO	A-F ≠	A-F	VOX, LIVE
RADIO & INTERCOM	ALL RADIOS	A-F	ALL	VOX, LIVE
* Intercom Audio Received Only While transmitting On Intercom Using Headset PTT ≠ Indicates Different settings for WORK and MONITOR Switches				

2.14. CHANGING SYSTEM CONFIGURATION.

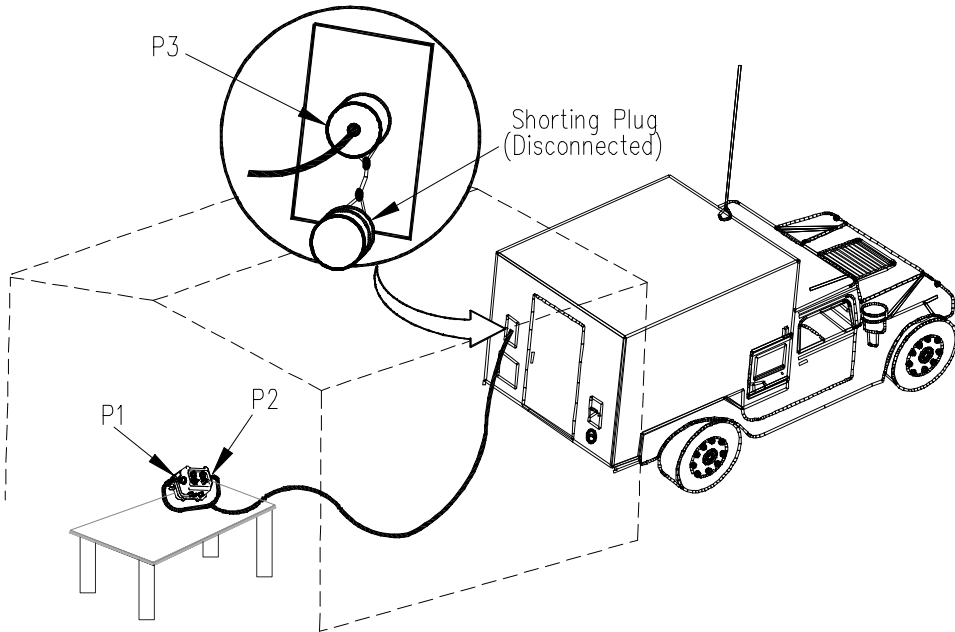

Figure 2-20. Installation of remote FFCS

2.14.1. Installation of Remote FFCS

- Disconnect Shorting Plug from external vehicle connector.
(See Figure 2-20)
- Connect P3 of branched cable to external vehicle connector.
- Connect P2 of branched cable to right side STATION connector of remote FFCS.
- Connect P1 of branched cable to left side STATION connector of remote FFCS.

2.14.2. Removal of Remote FFCS

- Remove P3 of branched cable from vehicle external connector.
- Connect shorting plug to vehicle external connector.
- Based on unit policy, either store FFCS attached to branched cable or remove cable from FFCS and store each separately. Insure that stored items are properly located and secure so they do not interfere with operations and are not subject to accidental damage.

2.15. WEARING CVC, CAPS, ACAPS, AND CCH HEADSETS

The following paragraphs describe how to properly wear the various headsets used in VIS.

2.15.1. CVC HEADSET

PUTTING ON THE CVC HEADSET (Figure 2-21)

- a. If this is the initial fitting of your headset, release the velcro straps on the impact liner above each earcup and across the back of your neck (nape adjustment).
- b. Place the impact liner on your head with each ear entirely within the corresponding ear seal.
- c. Rotate the earcups, as required, to provide as much comfort as possible with the earseals tight against your head.
- d. Take up slack in the velcro straps at back of your neck and then the straps above the earcups. Adjust tension so that the earseal is tight against your head with each ear totally enclosed within the earseal.
- e. Place the outer shell over the impact liner so that the rubber edging of the forehead portion of the outer shell is even with the edge of the browpad on the impact liner.
- f. Attach the snap fasteners of the outer shell to the fasteners of the liner located at the left and right temple areas.
- g. Push down on the outer shell to engage the velcro patch on the top of the impact liner with and the velcro patch inside the outer shell.
- h. Attach the snap fastener at the rear of the impact liner to the fastener at the rear of the outer shell.
- i. Place the chin strap under your chin and attach the chin strap snap fasteners to each side of the impact liner.
- j. Adjust tension of the chin strap to keep the earseals tight against your head. To increase tension, pull on the webbing attached to the buckle; to release tension, pull the leather tab attached to the buckle.

NOTE

Keep chin strap fastened and tight at all times to keep the earseals tight against your head to obtain maximum sound protection.

- k. Check that the microphone tip is centered on and 1/4 inch from your lips.

NOTE

Microphone must be close to your lips for noise cancellation to be fully effective.

- l. If adjustment is required, adjust microphone knuckle to place microphone tip as close as possible to being centered on and 1/4 inch from your lips.

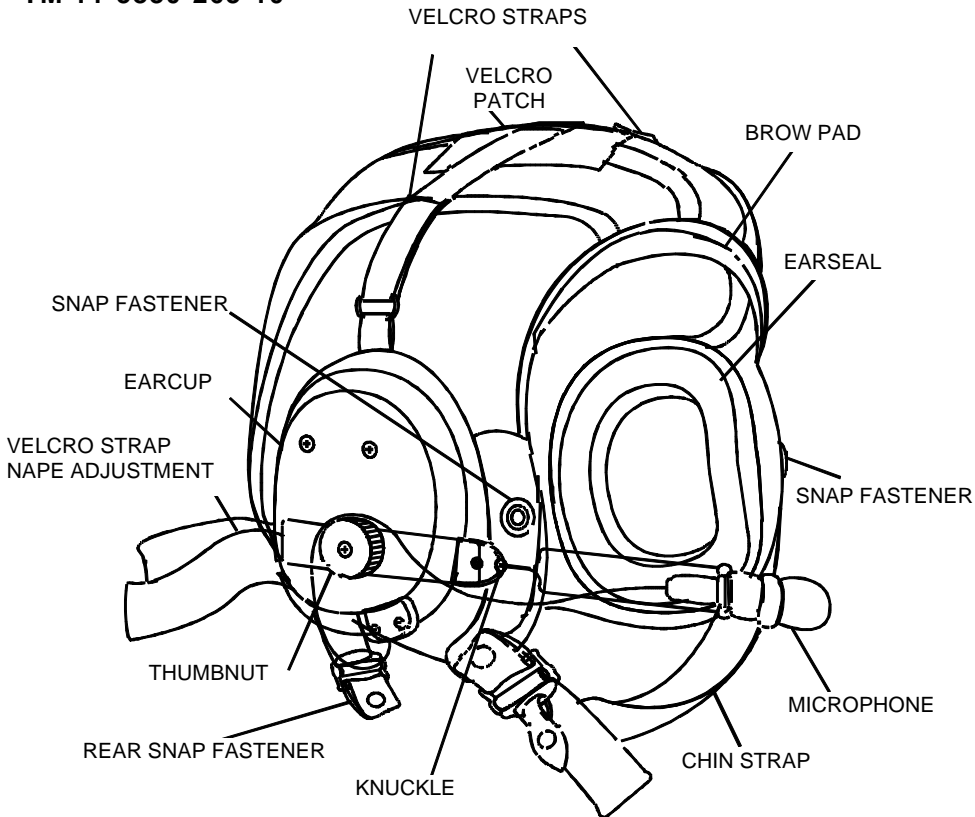

Figure 2-21. Wearing the CVC Headset

m. If microphone needs further adjustment, loosen thumbnut on right earcup (and if necessary thumb screw at base of microphone) and reposition microphone to bring the microphone to the centered, 1/4 inch spacing and tighten the thumbnut and thumbscrew.

n. If this has been the initial fitting of the headset, feel the strap attaching the strap fastener at the rear of the shell. If there is slack in the strap, remove the helmet and liner and adjust the strap to eliminate slack.

REMOVING THE CVC HEADSET

a. Unfasten the snap fastener on the right side of the chin strap.

b. Grasp the earcups and, while pulling them outward, lift the headset and impact liner up and away from your head.

2.15.2. CAPS AND ACAPS HEADSETS

The CAPS headset can be placed on the head and removed without helmet removal. The rear mounted neckband is adjustable to help keep uniform pressure between the earseals and your head.

NOTE

Ensure that the CAPS/ACAPS headset is properly adjusted. An improper seal between the earseal and the head may result in a low frequency tone in the headset when the ANR circuits are switched on. If this occurs, re-adjust the headset.

PUTTING ON THE CAPS/ACAPS HEADSET (Figure 2-23)

a. Prior to putting on the headset, put on your helmet, fasten the helmet chinstrap, and adjust it to secure the helmet

NOTE

There are two adjustments that affect the space between your head and your helmet into which the CAPS/ACAPS headset will be inserted. See Figure 2-22. If these helmet adjustments are not made properly prior to insertion of the headset, comfort may be adversely affected

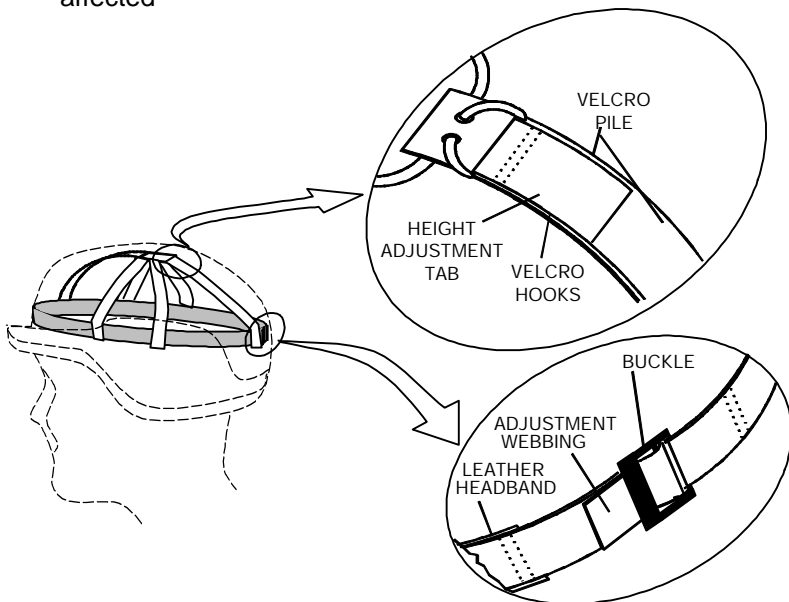

Figure 2-22. Helmet Adjustments

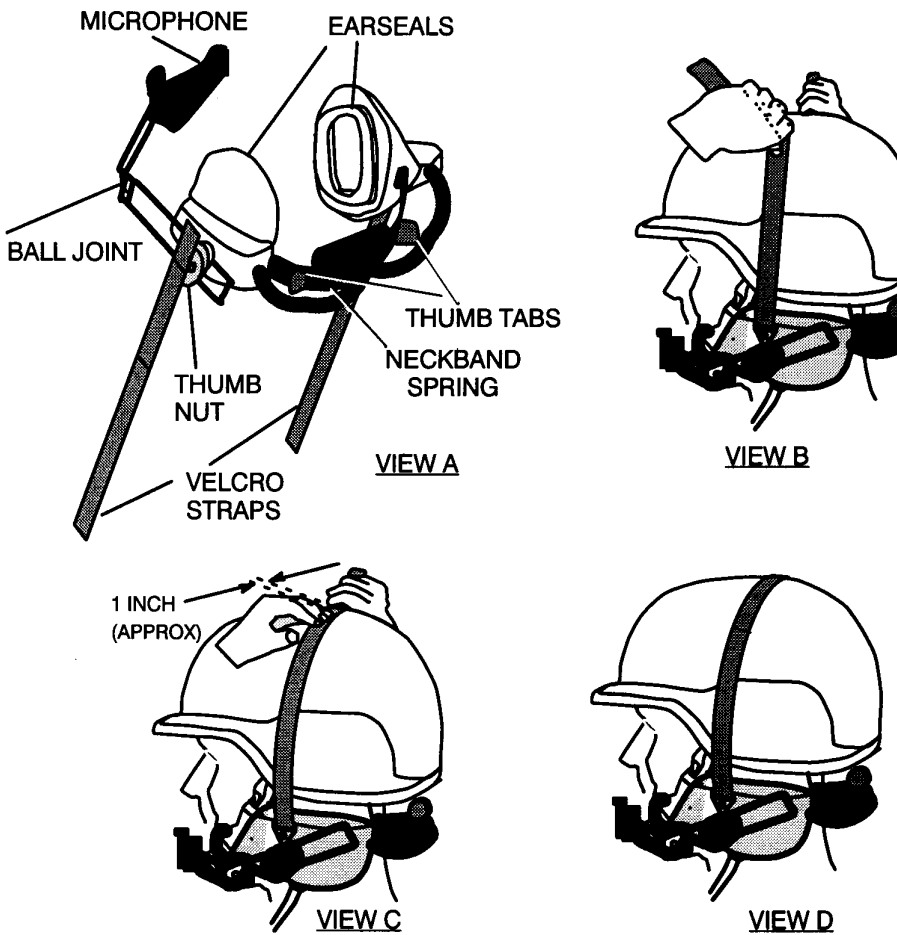

Figure 2-23. Wearing the CAPS/ACAPS Headsets

- b. Insure that the velcro straps on the headset are not engaged (View A).
- c. With the earcup containing the microphone in your left hand and the other earcup in your right, place the headset behind your head.
- d. Spread the earcups apart and slide them up inside the helmet over your ears behind the chin strap.
- e. Adjust the earcups so that each ear is entirely within the corresponding earseal.
- f. Pull up on the both velcro straps to support the headset and produce the most uniform pressure between the earseals and your head (View B).
- g. While keeping both straps tight, place the left strap against the helmet and press it against the helmet with your fingers located about one inch from the end of the strap (View C).
- h. Pull up on the right velcro strap to support the earcup and produce the most uniform pressure between the right earseal and your head.

i. While keeping the right strap tight, press it against free end of the the left strap and smooth the right strap over the left with enough pressure to engage the velcro fasteners (View D).

j. Check that the headset is tightly secured to the helmet and retighten if necessary to obtain the best sealing of the earseals against the head.

k. Using the thumb tabs between the neckband and each earcup (View A), adjust the spread of the earcups to provide: (1) the best seal to your head entirely around each ear and (2) as much comfort as possible.

NOTE

Moving the tabs apart angles the earcups to increase pressure against your head at the rear.
Moving the tabs together angles the earcups to increase pressure against your head at the front.

l. Check that the microphone tip is centered on and 1/4 inch from your lips.

NOTE

Microphone must be close to your lips for noise cancellation to be fully effective.

m. If adjustment is required, adjust microphone ball joint to place microphone tip as close as possible to being centered on and 1/4 inch from your lips.

n. If microphone needs further adjustment, loosen thumbnut on left earcup (and, if necessary, pivot microphone) and reposition microphone to bring the microphone to the centered, 1/4 inch spacing and tighten the thumb nut.

NOTE

If this is the first fitting of your headset and some discomfort is noted, re-check the adjustments of your helmet (Figure 2-22) and your headset (steps b. through k. above). If serious discomfort can not be alleviated by careful adjustment of helmet and headset (including disconnecting the camouflage cover straps if too tightly stretched across the recess in the helmet) request exchange of your helmet for the next larger size.

REMOVING THE CAPS/ACAPS HEADSET

- a. Unfasten the velcro straps on top of the helmet.
- b. Slide the earcups down and to the rear.
- c. Grasp the earcups and spread them apart.
- d. If ACAPS headset, check that ANR/OFF/TTC switch is in the off position.

2.15.3. CCH HEADSET

a. Spread the earcup and side pad and place the headset onto the head with the overhead band comfortably positioned. See figure 2-24.

b. Loosen both adjustment knobs and slide the spring elements up or down until your ear is centered in the earcup and the headset fits comfortably on your head. Then tighten the adjustment knobs.

c. Position the microphone by use of the knuckle-ball joint, the swivel, and the thumbscrew as necessary. The microphone can be worn on the left-hand or right-hand side by swiveling the boom assembly to the desired position before placing the headset on the head. Position the microphone approximately 1/4 inch from the mouth.

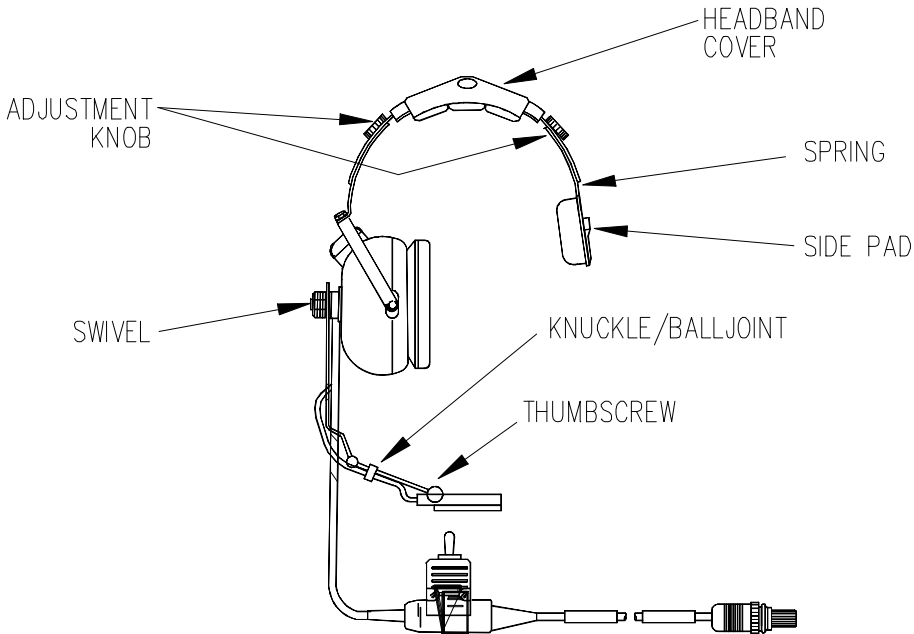

Figure 2-24. Wearing the CCH Headset

SECTION III. OPERATION UNDER UNUSUAL CONDITIONS

2.16. OPERATION IN UNUSUAL WEATHER CONDITIONS.

For procedures necessary to operate VIS equipment in cold weather, refer to FM 31-70. For procedures necessary to operate VIS equipment in mountain conditions, refer to FM 31-72. For procedures necessary to operate VIS equipment in northern conditions, refer to FM 31-71.

2.17. NUCLEAR, BIOLOGICAL, AND CHEMICAL (NBC) DECONTAMINATION PROCEDURES.

For procedures necessary to decontaminate VIS equipment during NBC warfare conditions, see Chemical, Biological, and Radiological (CBR) Decontamination manual TM 3-220.

CHAPTER 3 OPERATOR MAINTENANCE INSTRUCTIONS

	Page
SECTION I. Operator PMCS	3-1
SECTION II. Operator Troubleshooting Procedures	3-5

SECTION I. OPERATOR PREVENTIVE MAINTENANCE CHECKS AND SERVICES (PMCS)

3.1. SCOPE OF OPERATOR MAINTENANCE

The maintenance duties of the operator are to perform a prescribed sequence of preventive maintenance checks and services. The preventive maintenance procedures are the systematic care, servicing, and inspection of equipment to prevent the occurrence of trouble and to reduce downtime by detecting and correcting problems at the onset of trouble. These checks and services are performed to maintain the equipment in combat-serviceable and mission-ready condition.

3.2. TOOLS, MATERIAL, AND EQUIPMENT REQUIRED FOR OPERATOR MAINTENANCE

No tools or equipment are required for maintenance by the operator. The materials in Appendix B are required for cleaning and servicing the equipment. Records and reports of preventive maintenance checks and services must be made in accordance with the requirements set forth in DA PAM 738-750.

3.3. GENERAL PMCS PROCEDURES

NOTE

The term “mission capable” means the equipment is on hand and able to perform its function.

Table 3-1. Operator Preventive Maintenance Checks and Services

Item No.	Interval	Item to Check or Service	Procedure	Not Fully Mission Capable if:
1	Daily	Headsets	Check to see if cable insulation is not damaged. Check to see if windscreen is in place on the microphone.	

Item No.	Interval	Item to Check or Service	Procedure	Not Fully Mission Capable if:
2	Daily	Functionality of VIS Units	<p>Check to see if microphone boom assembly functions to hold microphone in desired position in front of the user's mouth.</p> <p>Check to see if both earcup assemblies are not damaged.</p> <p>Check each headset at each VIS unit for satisfactory intercom operation including ANR.</p> <p>When a telephone is connected to the intercom system at the MCS, perform a check of the intercom using the telephone.</p>	Headset fails to transmit or receive.
3	Weekly	Headsets	Clean external parts of the headsets. Clean helmets inside and outside.	
4	Weekly	VIS Units	<p>Clean the exterior surfaces of the VIS boxes.</p> <p>Check to see that dust covers are installed on unused cable receptacles.</p> <p>Check to see that locknuts of headset receptacles are tight.</p> <p>Check to see that connectors of cables to vehicle outlets are tight.</p>	Cables are damaged or loose. Radio/Intercom communication may be degraded.
5	Bi-Monthly	ACAPS/ PICVC Headsets	Replace alkaline battery in ACAPS/ PICVC headset. (Remove and replace rechargeable battery in PICVC headsets as needed.	
6	Quarterly	Headsets	<p>Check headset for cracked cable insulation or if any parts are broken.</p> <p>Check headset bailout cable connector to see if gland nut is tight.</p>	

Item No.	Interval	Item to Check or Service	Procedure	Not Fully Mission Capable if:
7	Quarterly	VIS Units	Check to see that metal surfaces are free of rust and corrosion.	
8	Quarterly	Radio-Intercom System Cabling	Check to see that dust covers are on unused receptacles. Check to see that cables are not damaged and that they are locked to the equipment receptacles.	Cables are damaged or loose. Radio/Intercom communication may be degraded.
9	As required	Headset Cable Connector	Check to see that all cable clamps are in place, that they hold the cables securely, and that the cable clamp screws are screwed down tightly. Lubricate O-ring in headset bailout cable connector if connection to FFCS, MOS or Alarm Cable is difficult.	

3.4. CLEANING EQUIPMENT

The exterior surfaces of the equipment should be clean. There should be no dust, dirt, grease, oil, or fungus on the surfaces.

Remove dust and loose dirt with a clean cloth.

Remove grease, oil, fumes, and ground-in dirt from equipment with a clean cloth dampened (not wet) with isopropyl alcohol or general purpose detergent.

If the equipment is washed down using a water hose, do not direct the water directly at the front panels and cable connectors. Wipe the equipment dry after using the water hose.

3.5. USING LUBRICANTS ON CONNECTING SURFACES

WARNING

DISCONNECTING OR BYPASSING THE VEHICULAR INTERCOMMUNICATION SYSTEM (VIS) ALARM CABLE CONNECTED TO THE DRIVER'S FULL FUNCTION CREW STATION (FFCS) BY THE VEHICLE CREWMAN IS PROHIBITED. SUCH ACTION MAY RESULT IN INJURY OR DEATH. EQUIPMENT DAMAGE MAY ALSO RESULT. THIS CABLE ENABLES THE VEHICLE HAZARD WARNING TONES TO BE INSERTED DIRECTLY INTO THE INTERCOM SYSTEM, SO THAT THESE WARNING TONES CAN BE INSTANTLY HEARD BY ALL OF THE VEHICLE CREWMEMBERS. ONLY THE UNIT MAINTAINER IS AUTHORIZED TO REMOVE AND REPLACE THE ALARM CABLE. REFER TO THE APPROPRIATE VIS TECHNICAL PUBLICATIONS FOR OPERATOR, INSTALLATION, AND MAINTENANCE INSTRUCTIONS.

CAUTION

Do not let the silicone compound touch electrical contacts or surfaces.

NOTE

During vehicle operation tank crewmen are only authorized to disconnect the drop cord [attached to the left ear cup of the Combat Vehicle Crewman (CVC) Headset] from the Bailout Cable Assembly (Spaghetti Cord). This cable is connected directly to the VIS FFCS or Driver Alarm Cable. No other VIS cables may be removed/bypassed/replaced by the crewman. During PMCS only the Bailout Cable Assembly may be disconnected from the FFCS or Alarm Cable for cleaning and application of silicone gel to the connector O-ring. Upon completion of PMCS the Bailout Cable Assembly(s) should immediately be re-connected. Refer to the VIS Operator's Manual for instructions. All other maintenance should be referred to the Unit Maintainer.

1. Clean the surfaces of headset bailout cable connector O-rings (see figure 3-1).
2. Apply silicone compound to headset bailout cable connector O-rings.

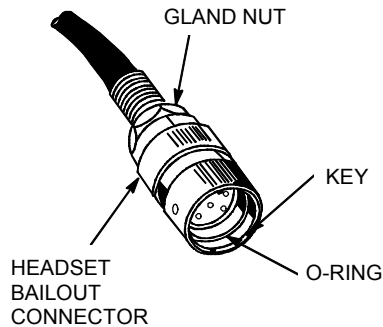

Figure 3-1. Details of Cable Connector

3.6. BATTERY REMOVAL AND REPLACEMENT

WARNING

ALKALINE BATTERIES CONTAIN CAUSTIC KOH ELECTROLYTE, WHICH MAY LEAK IF THE BATTERY IS ABUSED. KOH IS A STRONG ALKALI SIMILAR TO CAUSTIC SODA (SODIUM HYDROXIDE). SERIOUS CHEMICAL BURNS CAN RESULT IF ELECTROLYTE COMES INTO CONTACT WITH THE SKIN OR EYES. IF THE BATTERY ELECTROLYTE GETS INTO YOUR EYES, IT CAN CAUSE SEVERE DAMAGE AND/OR BLINDNESS.

DO NOT TRY TO NEUTRALIZE CAUSTIC ELECTROLYTE WITH VINEGAR OR ANY OTHER ACIDIC SOLUTIONS. NEUTRALIZATION WILL DO MORE HARM THAN GOOD, AS IT WILL TRAP CAUSTIC UNDER THE SKIN, PREVENTING IT FROM COMING OUT. FLUSH WITH COPIOUS AMOUNTS OF COOL WATER.

3.6.1 ACAPS HEADSET ALKALINE BATTERY REMOVAL AND REPLACEMENT

1. Rotate battery cover counterclockwise and remove. (See Figure 3-2.)
2. Remove battery from compartment.
3. Insert replacement battery negative end first into battery compartment.
4. Align ridges inside battery cover with slots on the battery compartment, when aligned push in and turn clockwise until secure.

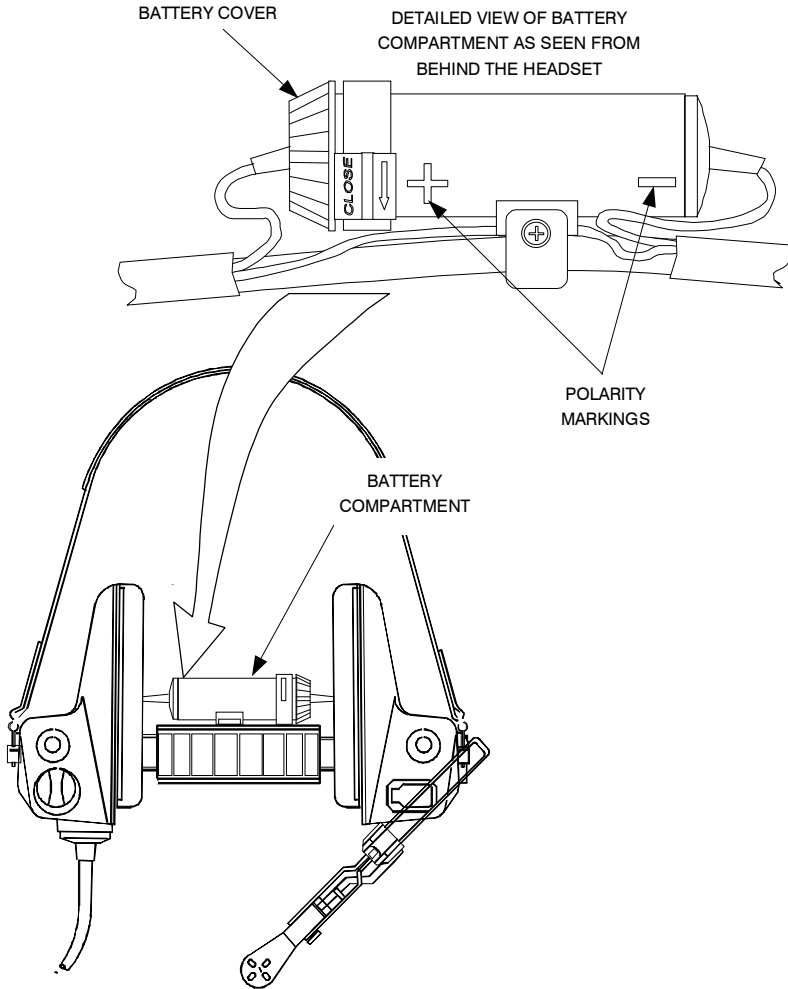

Figure 3-2. Details of ACAPS Battery Compartment

3.6.1 CVC HEADSET BATTERY REMOVAL AND REPLACEMENT

NOTE

Using a rechargeable battery containing memory (for example, Nickel Cadmium, NiCAD) is not recommended. Memory type batteries should be fully discharged before recharging. Since the operational scenario of VIS results in constant recharging of the battery when the headset is connected to a FFCS or MOS, using a memory type battery will result in shorter battery life.

1. Using a flat head screwdriver (if authorized) or a small coin, loosen two captive screws and remove battery compartment cover. (See Figure 3-3.)
2. Remove battery from compartment.
3. Insert replacement alkaline or rechargeable (Nickel Metal Hydride, NiMH) battery into the appropriately marked slot in the battery compartment, observing polarity.
4. Replace battery compartment cover and tighten captive screws until secure.

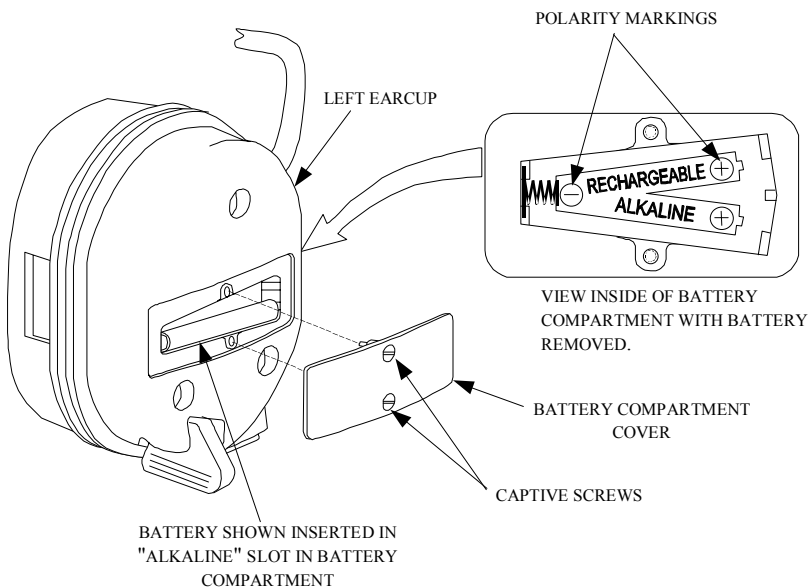

Figure 3-3. Details of CVC Battery Compartment

SECTION II. OPERATOR TROUBLESHOOTING PROCEDURES

3.7. TROUBLESHOOTING BY VISUAL INSPECTION

Problem resolution concerning the VIS begins by observing the alphanumeric display of the MCS. After initial turn-on of the system, the Built-In-Test (BIT) checks the system for faults and displays any errors. If any codes appear on the display other than normal operating codes that do not clear when power is cycled to OFF then to on (PROG 1, 2, or 3), unit-level maintenance is required. The following steps deal with other potential problems.

3.7.1. Power Failure

If during operation of the radio or radio-intercom equipment, the system seems to lose power, make the following checks:

If the vehicle has a master switch and/or master circuit breaker, check to see that it is turned on.

Check to see that the radio is pushed back fully on its mount and that the mounting clamps are tightened fully.

Check to see that the power cable is connected to the MCS and the SYSTEM switch is **not** in the OFF position

3.7.2. Communication Failures While Using VIS

When radio or intercom communication failures occur while using headsets connected to the VIS, make the following checks:

Check to see that the headset cable connectors are locked on the VIS unit receptacles.

Check to see if all cables connected to the MCS are fastened securely.

If an FFCS fails while the turret is being turned, the turret slip rings may be at fault.

If an FFCS is inoperative, check that cabling is securely fastened between the FFCS and the VIS units connected to both sides of the FFCS.

3.8. PROCEDURES FOR OPERATOR TO TROUBLESHOOT VIS

Accurate operator troubleshooting requires all cables to be properly connected and all FFCS/RITs to have the correct settings.

Table 3-2. Troubleshooting VIS Chart

Item Number	Symptom	Probable Causes	Corrective Measures
1	Vehicle master circuit breaker trips when set to ON.	Defective MCS, Defective power cable assembly. Defective vehicle wiring	Reset vehicle master circuit breaker. If fault remains unit-level maintenance is required.
2	MCS display does not light when SYSTEM switch is in position other than OFF.	Power is turned off.	Check that the vehicle master circuit breaker is in the ON position. If fault remains unit-level maintenance is required.
4	MCS ANR Power Fault LED illuminates.	ANR power overload.	Switch the MCS off and back on again. If fault remains unit-level maintenance is required.
5	Alphanumeric display shows an error message 1c/2c/3c/rc/etc	MCS was programmed without configuring the system	Do system configuration procedures (Para 2.10.1a) If fault remains unit-level maintenance is required.
6	Alphanumeric display error message	Various	Switch the MCS off and back on again. If fault remains unit-level maintenance is required.

APPENDIX A

REFERENCES

A-1. Scope

This appendix lists all forms, field manuals, technical manuals, and miscellaneous publication used for reference in this manual.

A-2. Forms

DA Form 2028-2	Recommended Changes to Equipment Technical Publications
DA Form 2404	Equipment Inspection and Maintenance Worksheet
SF 361	Discrepancy in Shipment Report (DISREP)
SF 364	Report of Discrepancy (TDR)
SF 368	Product Quality Deficiency Report (ROD)

A-3. Field Manuals

FM 31-70	Basic Cold Weather Manual
FM 31-71	Northern Operations Manual
FM 31-72	Mountain Operations Manual

A-4. Technical Manuals

TM 3-220	Chemical, Biological, and Radiological (CBR) Decontamination Manual
TM 11-5805-201-12	Operator's and Unit Maintenance Manual for Telephone Sets, TA-312/PT and TA-312A/PT
TM 11-5820-401-10-1	VRC-12 Family of Radios, Operator's Manual (used without Intercom Systems)
TM 11-5820-401-10-2	VRC-12 Family of Radios, Operator's Manual (used with Intercom Systems)
TM 11-5820-401-20-1	VRC-12 Family of Radios, Organizational Maintenance Manual (used without Intercom Set)
TM 11-5820-401-20-2	VRC-12 Family of Radios, Organizational Maintenance Manual (used with Intercom Set AN/VIC-1(V))
TM 11-5820-890-10-3	Operator's Manual (Non-ICOM Radio Sets)
TM 11-5820-890-10-8	Operator's Manual (ICOM Radio Sets)
TM 11-5820-890-20-1	Unit Maintenance Manual (ICOM Radio Sets) (Volume 1)

TM 11-5830-263-10

TM 11-5820-890-20-2	Unit Maintenance Manual (ICOM Radio Sets) (Volume 2)
TM 11-5820-890-20-3	Unit Maintenance Manual (ICOM Radio Sets) (Volume 3 Handbook)
TM 11-5820-890-20-4	Unit Maintenance Manual (Non-ICOM Radio Sets)
TM 11-5820-923-12	Operator's and Organizational Maintenance Manual for Radio Set, AN/GRC-213
TM 11-5830-340-12	Operator's and Organizational Maintenance Manual, Intercommunication Set, AN/VIC-1(V)
TM 11-5830-263-10	Operator's Manual Intercommunication Set AN/VIC -3(V)
TM 11-5830-263-20&P	Unit Maintenance Manual Intercommunication Set AN/VIC -3(V)
TM 746-10	General Packaging Instructions for Field Units Subscription Form
TM 750-244-2	Procedure for Destruction of Electronics Material to Prevent Enemy Use (Electronics Command)
TB 11-5830-263-20-1	Installation Instructions For Vehicular Intercommunication Set AN/VIC-3(V)1 in a Tank, Combat, Full Tracked: M1A1 Abrams
TB 11-5830-263-20-2	Installation Instructions For Vehicular Intercommunication Set AN/VIC-3(V)2 in a Tank, Combat, Full Tracked: M1A2 Abrams
TB 11-5830-263-20-3	Installation Instructions For Vehicular Intercommunication Set AN/VIC-3(V)3 in an M2A2 Bradley Fighting Vehicle
TB 11-5830-263-20-4	Installation Instructions For Vehicular Intercommunication Set AN/VIC-3(V)4 in an M3A2 Bradley Fighting Vehicle
TB 11-5830-263-20-5	Installation Instructions For Vehicular Intercommunication Set AN/VIC-3(V)5 in an M577 Command Post Vehicle
TB 11-5830-263-20-6	Installation Instructions For Vehicular Intercommunication Set AN/VIC-3(V)6 in an M109A6 Paladin Vehicle
TB 11-5830-263-20-7	Installation Instructions For Vehicular Intercommunication Set AN/VIC-3(V)7 in an M1068 SICPS Tracked Vehicle
TB 11-5830-263-20-8	Installation Instructions For Vehicular Intercommunication Set AN/VIC-3(V)8 in an S-787 SICPS Rigid Wall Shelter (RWS) Vehicle
TB 11-5830-263-20-9	Installation Instructions For Vehicular Intercommunication Set AN/VIC-3(V)9 in an M2A2 ODS Bradley Fighting Vehicle

TB 11-5830-263-20-10	Installation Instructions For Vehicular Intercommunication Set AN/VIC-3(V)10 in an M3A2 ODS Bradley Fighting Vehicle
TB 11-5830-263-20-11	Installation Instructions For Vehicular Intercommunication Set AN/VIC-3(V)11 in an Heavy Assault Bridge Vehicle
TB 11-5830-263-20-12	Installation Instructions For Vehicular Intercommunication Set AN/VIC-3(V)12 in an M992 Field Artillery Ammunition Support Vehicle
TB 11-5830-263-20-13	Installation Instructions For Vehicular Intercommunication Set AN/VIC-3(V)13 in an M7 Bradley Fire Support Team Vehicle
TB 11-5830-263-20-14	Installation Instructions For Vehicular Intercommunication Set AN/VIC-3(V)14 in an M88A2 Recovery Vehicle
TB 11-5830-263-20-15	Installation Instructions For Vehicular Intercommunication Set AN/VIC-3(V)15 in an Armored Security Vehicle
TB 11-5830-263-20-16	Installation Instructions For Vehicular Intercommunication Set AN/VIC-3(V)16 in an MLRS Vehicle
TB 11-5830-263-20-17	Installation Instructions For Vehicular Intercommunication Set AN/VIC-3(V)17 in a Grizzly (Breacher) Vehicle
TB 11-5830-263-20-18	Installation Instructions For Vehicular Intercommunication Set AN/VIC-3(V)18 in a Striker Vehicle

A-5. Miscellaneous Publications

AMDF	Army Master Data File (Microfiche)
AR 55-38	Transportation Deficiency Report (TDR)
AR 380-5	Department of the Army Information Security Program Subscription Form
AR 710-2	Supply Policy Below the Wholesale Level as Contained in Unit Supply UPDATE
AR 725-50	Requisitioning, Receipt and Issuing System in UPDATE
AR 735-11-2	Report of Discrepancy (ROD)
DA PAM 25-30	Consolidated Index of Army Publications (Microfiche)
DA PAM 710-2-1	Using Unit Supply System Manual Procedures as Contained in Unit Supply UPDATE
DA PAM 738-750	Maintenance Management Update
SB 11-131-2	Vehicular Radio Sets and Authorized Installations (SINCGARS)
SB 11-573	Painting and Preservation of Supplies Available for Field Use for Electronics Command Equipment

APPENDIX B
COMPONENTS OF END ITEM AND BASIC ISSUE
ITEMS LIST

SECTION I. INTRODUCTION
NOT APPLICABLE

SECTION II. COMPONENTS OF END ITEM LIST
FOR
AN/VIC-3(V)

NOT APPLICABLE

SECTION III. BASIC ISSUE ITEMS
FOR
AN/VIC-3(V)

TM 11-5830-263-10	Operator's Manual Intercommunication Set AN/VIC -3(V)
-------------------	--

APPENDIX C ADDITIONAL AUTHORIZATION LIST

SECTION I. INTRODUCTION

C-1. SCOPE

This appendix lists additional items you are authorized for the support of the AN/VIC-3(V).

C-2. GENERAL

This list identifies items that do not have to accompany the AN/VIC-3(V) and that do not have to be turned in with it. These items are all authorized to you by Common Table of Allowances (CTA), Modified Table of Organization and Equipment (MTOE), Table of Distribution and Allowances (TDA), or Joint Table of Allowances (JTA).

C-3. EXPLANATION OF LISTING

National stock numbers, descriptions, and quantities are provided to help you identify and request the additional items you require to support this equipment.

SECTION II. ADDITIONAL AUTHORIZATION LIST FOR AN/VIC-3(V)

Key	National stock number	Description FSCM & part number	Usable on code	U/M	Qty auth
	6135-00-985-7845	Battery, Non-recharge (90303), MN1500	KDX	PG	

APPENDIX D

EXPENDABLE/DURABLE SUPPLIES AND MATERIALS LIST

SECTION I. INTRODUCTION

D-1. SCOPE

This appendix lists expendable and/or durable supplies and materials you will need to operate and maintain the AN/VIC-3(V) system. These items are authorized to you by CTA 50-970, Expendable items (Except Medical, Class V, Repair Parts, and Heraldic Items).

D-2. EXPLANATION OF COLUMNS

a. Column (1) - Item Number. This number is assigned to the entry in the listing for reference purposes.

b. Column (2) - Level. This column identifies the lowest level of maintenance that requires the listed item.

(enter as applicable)

C - Operator/Crew

O - Unit Maintenance

F - Intermediate Direct Support Maintenance

H - Intermediate General Support Maintenance

c. Column (3) - National Stock Number. This is the national stock number assigned to the item; use it to request or requisition the item.

d. Column (4) - Description. Indicates the Federal item name and, if required, description to identify the item. The last line for each item indicates the Federal Supply Code for Manufacturer (FSCM) in parentheses followed by the part number.

e. Column (5) - Unit of Measure (U/M). Indicates the measure used in performing the actual maintenance function. This measure is expressed by a two-character alphabetical abbreviation (e.g., ea, in, pr). If the unit of measure differs from the unit of issue, requisition the lowest unit of issue that will satisfy your requirements.

**SECTION II. EXPENDABLE/DURABLE SUPPLIES AND
MATERIALS
FOR AN/VIC-3(V)**

(1) Item No.	(2) Level	(3) National Stock Number	(4) Description	(5) U/M
1.	C	7920-00-044-9281	Cleaning, Cloth (81349), MIL-C-85043	BX
2.	C	6810-00-292-9625	Degreasing Solvent (83574), PR146BLUE	QT
3.	C	6850-00-664-4959	Silicone Compound (71984), DC 6	GL
4.	C	7930-00-282-9699	Detergent, General Purpose (81349), MIL-D-16791	GL
5.	C	5975-01-133-8696	Strap, Tiedown (96906), MS3367-6-9	HD
6.	C	7930-00-282-9699	Isopropal Alcohol	CN

APPENDIX E

ACRONYMS AND TERMS

SECTION I. INTRODUCTION

E-1. GENERAL

a. This section provides a list of acronyms and terms used in this technical manual. Definitions of all the terms are given.

TERM	DEFINITIONS
ACAPS	Artillery Communication Aural Protective System
ANR	Active Noise Reduction
ARC	Auto Reconnect Circuit
ASSY	Assembly
BIT	Built-In-Test
CAPS	Communication Aural Protective System
CBR	Chemical, Biological, and Radiological Decontamination
CCH	Command and Control Headset
CECOM	Communications-Electronic Command
CPM	Continuous Performance Monitoring
CPV	Command Post Vehicle
CVC	Combat Vehicle Crewman
dB	Decibels (Unit of measure for sound level)
DISREP	Discrepancy In Shipment Report
EIR	Equipment Improvement Recommendations
FFCS	Full Function Crew Station
INT	Intercom
LIVE	Microphone on headset is always on
LS	Loudspeaker
MCS	Master Control Station
MONITOR	Receive communication over headset or loudspeaker
MOS	Monitor Only (Crew) Station
NSN	National Stock Number

TERM	DEFINITIONS
O/R	Override
PL	Parts List
PMCS	Preventative Maintenance Checks and Services
PTT	Push to Talk
RIT	Radio Interface Terminal
ROD	Report Of Discrepancy
SICPS	Standard Integrated Command Post System
SINGARS	Single Channel Ground-to-Air Radio System
TAMMS	The Army Maintenance Management System
TB	Technical Bulletin
TBD	To Be Determined
TDR	Transportation Deficiency Report
TM	Technical Manual
UL	Unit Level
VIS	Vehicular Intercommunications System
WK	Work
VOX	Voice Operated Switch

By Order of the Secretary of the Army:

DENNIS J. REIMER
General, United States Army
Chief of Staff

Official:



Administrative Assistant to the
Secretary of the Army
03657

DISTRIBUTION:

To be distributed in accordance with the initial distribution for (IDN) 389732, requirements for TM 11-5830-263-10

* U.S. GOVERNMENT PRINTING OFFICE: 1999 O - 454-114 (10826)

RECOMMENDED CHANGES TO EQUIPMENT TECHNICAL PUBLICATIONS

Something Wrong WITH THIS PUBLICATION



THEN ... JOT DOWN THE INFO ABOUT IT ON THIS FORM CAREFULLY TEAR IT OUT. FOLD IT AND DROP IT IN THE MAIL.

FROM (PRINT YOUR UNIT'S COMPLETE ADDRESS)

DATE SENT

PUBLICATION NUMBER PUBLICATION DATE PUBLICATION TITLE

BE EXACT PIN-POINT WHERE IT IS				IN THIS SPACE TELL WHAT IS WRONG AND WHAT SHOULD BE DONE ABOUT IT:
PAGE NO	PARA-GRAPH	FIGURE NO	TABLE NO	
				SAMPLE

TEAR ALONG DOTTED LINE

PRINTED NAME, GRADE OR TITLE AND TELEPHONE NUMBER SIGN HERE

REVERSE OF DA FORM 2028-2

FILL IN YOUR
UNIT'S ADDRESS

FOLD BACK

DEPARTMENT OF THE ARMY



OFFICIAL BUSINESS

PLEASE
AFFIX
STAMP
POSTAGE
REQUIRED

TEAR ALONG DOTTED LINE

**Commander
U.S. Army Communications-Electronics
Command
and Fort Monmouth
ATTN: AMSEL-LC-LEO-P-MM-T
Fort Monmouth, New Jersey 07703-5007**

THE METRIC SYSTEM AND EQUIVALENTS

WEIGHT MEASURE

1 Centimeter = 10 Millimeters = 0.01 Meters = 0.3937 Inches
 1 Meter = 100 Centimeters = 1000 Millimeters = 39.37 Inches
 1 Kilometer = 1000 Meters = 0.621 Miles

WEIGHTS

1 Gram = 0.001 Kilograms = 1000 Milligrams = 0.035 Ounces
 1 Kilogram = 1000 Grams = 2.2 lb.
 1 Metric Ton = 1000 Kilograms = 1 Megagram = 1.1 Short Tons

LIQUID MEASURE

1 Milliliter = 0.001 Liters = 0.0338 Fluid Ounces
 1 Liter = 1000 Milliliters = 33.82 Fluid Ounces

SQUARE MEASURE

1 Sq. Centimeter = 100 Sq. Millimeters = 0.155 Sq. Inches
 1 Sq. Meter = 10,000 Sq. Centimeters = 10.76 Sq. Feet
 1 Sq. Kilometer = 1,000,000 Sq. Meters = 0.386 Sq. Miles

CUBIC MEASURE

1 Cu. Centimeter = 1000 Cu. Millimeters = 0.06 Cu. Inches
 1 Cu. Meter = 1,000,000 Cu. Centimeters = 35.31 Cu. Feet

TEMPERATURE

$5/9(^{\circ}\text{F} - 32) = ^{\circ}\text{C}$
 212° Fahrenheit is equivalent to 100° Celsius
 90° Fahrenheit is equivalent to 32.2° Celsius
 32° Fahrenheit is equivalent to 0° Celsius
 $9/5^{\circ}\text{C} + 32 = ^{\circ}\text{F}$

APPROXIMATE CONVERSION FACTORS

TO CHANGE	TO	MULTIPLY BY
Inches	Centimeters	2.540
Feet	Meters	0.305
Yards	Meters	0.914
Miles	Kilometers	1.609
Square Inches	Square Centimeters	6.451
Square Feet	Square Meters	0.093
Square Yards	Square Meters	0.836
Square Miles	Square Kilometers	2.590
Acres	Square Hectometers	0.405
Cubic Feet	Cubic Meters	0.028
Cubic Yards	Cubic Meters	0.765
Fluid Ounces	Milliliters	29.573
its	Liters	0.473
arts	Liters	0.946
allons	Liters	3.785
Ounces	Grams	28.349
Pounds	Kilograms	0.454
Short Tons	Metric Tons	0.907
Pound-Feet	Newton-Meters	1.356
Pounds per Square Inch	Kilopascals	6.895
Miles per Gallon	Kilometers per Liter	0.425
Miles per Hour	Kilometers per Hour	1.609

TO CHANGE	TO	MULTIPLY BY
Centimeters	Inches	0.394
Meters	Feet	3.280
Meters	Yards	1.094
Kilometers	Miles	0.621
Square Centimeters	Square Inches	0.155
Square Meters	Square Feet	10.764
Square Meters	Square Yards	1.196
Square Kilometers	Square Miles	0.386
Square Hectometers	Acres	2.471
Cubic Meters	Cubic Feet	35.315
Cubic Meters	Cubic Yards	1.308
Milliliters	Fluid Ounces	0.034
Liters	Pints	2.113
Liters	Quarts	1.057
ers	Gallons	0.264
ms	Ounces	0.035
ograms	Pounds	2.205
Metric Tons	Short Tons	1.102
Newton-Meters	Pounds-Feet	0.738
Kilopascals	Pounds per Square Inch	0.145
ometers per Liter	Miles per Gallon	2.354
ometers per Hour	Miles per Hour	0.621

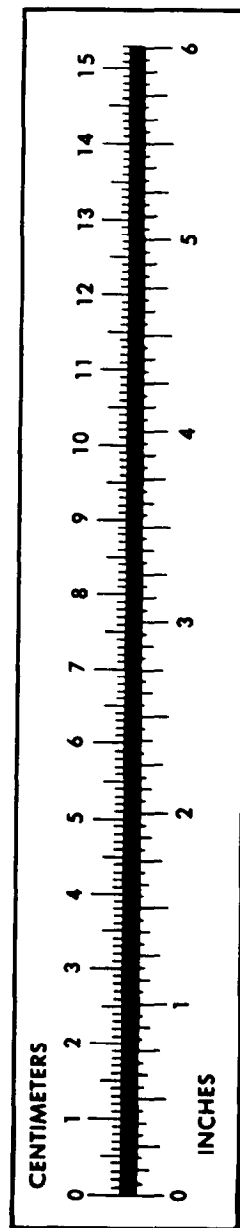

PIN: 075493-000